

(No Model.)

2 Sheets—Sheet 1.

C. D. SCOTT.  
TRAMWAY LOCOMOTIVE.

No. 504,541.

Patented Sept. 5, 1893.

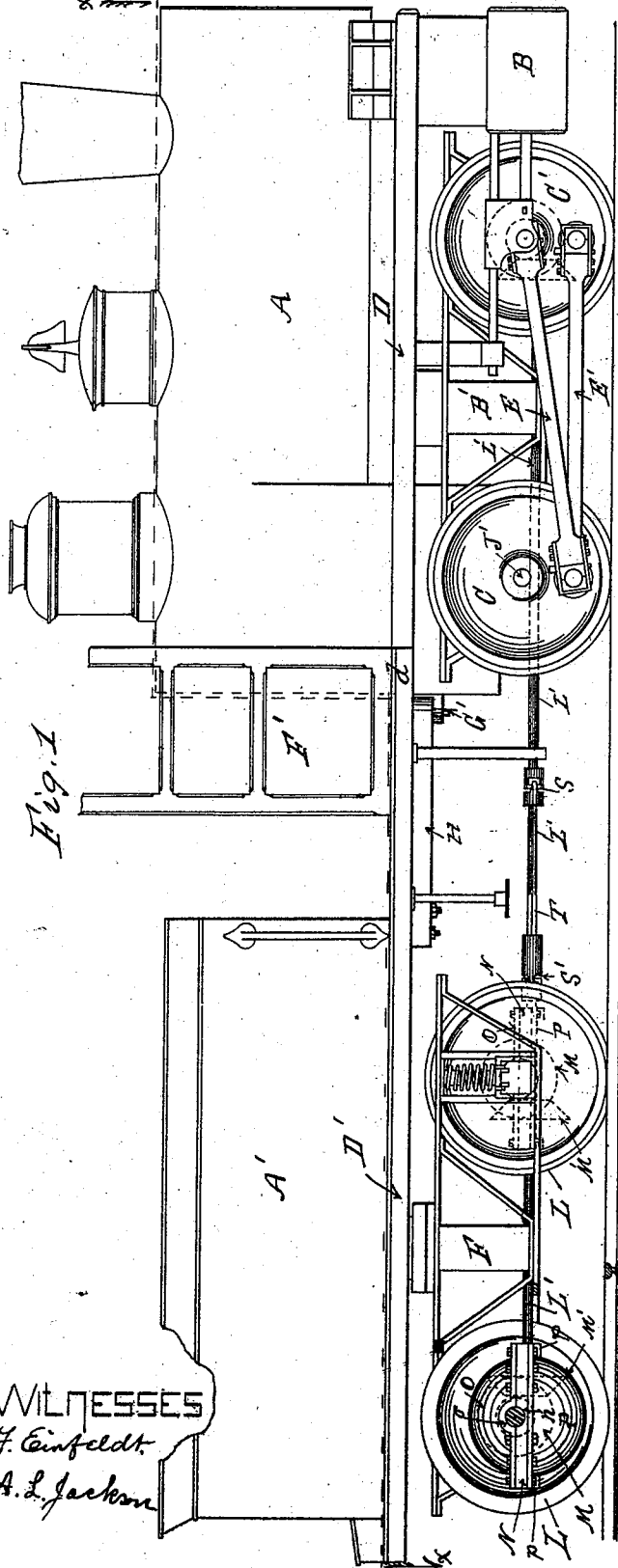

Fig. 1

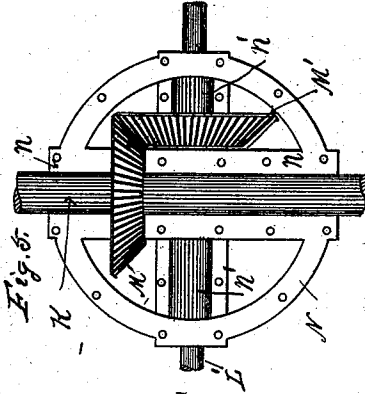

Fig. 2

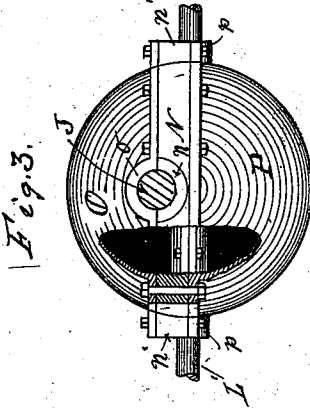

Fig. 3

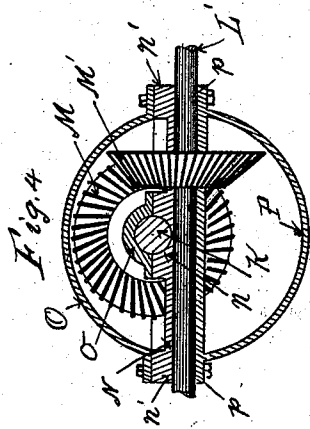

Fig. 4

WITNESSES  
 F. Einfeldt  
 A. L. Jackson

INVENTOR  
 Charles D. Scott  
 By J. S. [Signature]  
 Atty

(No Model.)

2 Sheets—Sheet 2.

C. D. SCOTT.  
TRAMWAY LOCOMOTIVE.

No. 504,541.

Patented Sept. 5, 1893.

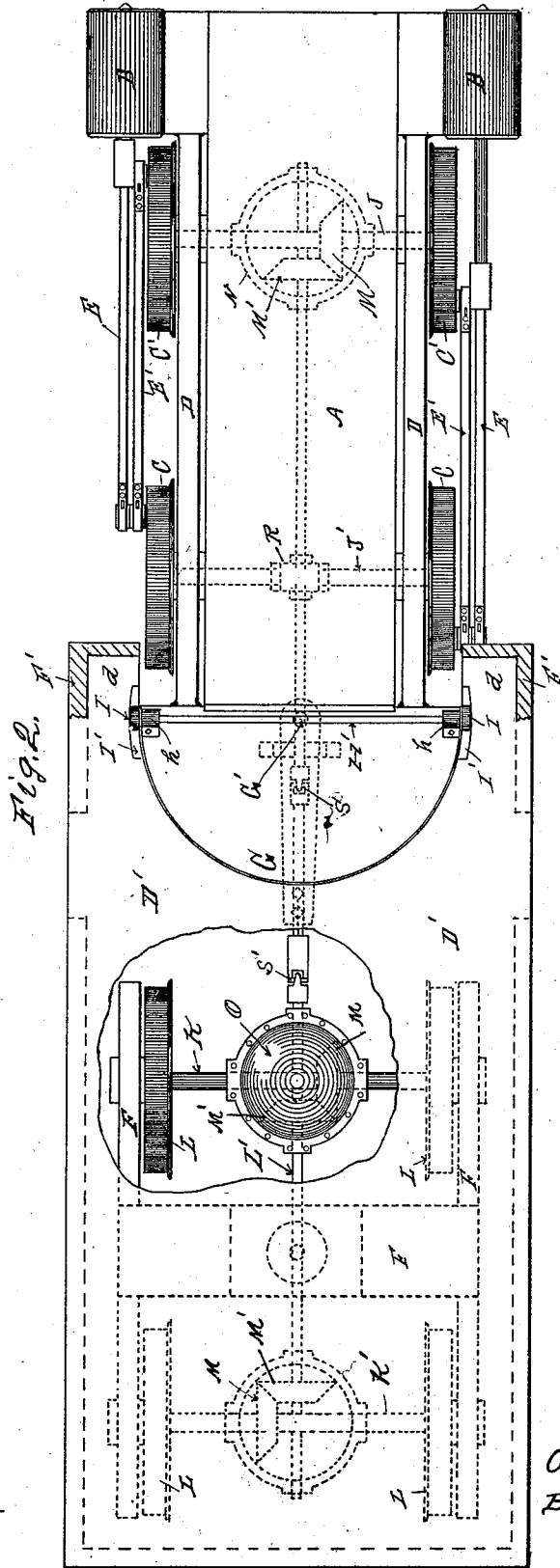

WITNESSES  
F. Einfeldt.  
A. L. Jackson

INVENTOR  
Charles D. Scott  
By H. Sturgeon  
Atty

# UNITED STATES PATENT OFFICE.

CHARLES D. SCOTT, OF CORRY, PENNSYLVANIA.

## TRAMWAY-LOCOMOTIVE.

SPECIFICATION forming part of Letters Patent No. 504,541, dated September 5, 1893.

Application filed March 31, 1893. Serial No. 468,594. (No model.)

*To all whom it may concern:*

Be it known that I, CHARLES D. SCOTT, a citizen of the United States, residing at Corry, in the county of Erie and State of Pennsylvania, have invented certain new and useful Improvements in Tramway-Locomotives; and I do hereby declare the following to be a full, clear, and exact description of the invention, such as will enable others skilled in the art to which it appertains to make and use the same, reference being had to the accompanying drawings, and to the letters of reference marked thereon, forming part of this specification.

My invention consists in the improvements in tramway locomotives, hereinafter set forth and explained and illustrated in the accompanying drawings in which—

Figure 1. is a side elevation of my improved tramway locomotive with portions thereof broken away. Fig. 2. is a longitudinal horizontal section of the same on the line  $x, x$ , in Fig. 1, with parts broken away. Figs. 3, 4, and 5. are details of the improved covered cross-box used in my improved tramway locomotive.

The objects of my invention are to provide a jointed line shaft geared by means of skew-gears to one of the axles of the wheels under the boiler and to the axles of the wheels of the tender, together with a joint in the frame or platform between the portion of the locomotive supporting the boiler and the frame or platform supporting the tank, fuel box and cab, whereby all of the wheels under the locomotive and tender operate as driving wheels, also to provide the cross-boxes on the axles which support the line shaft with covers forming parts of such cross-boxes, which completely inclose the skew-gears, and operate as receptacles for the material used for lubricating the skew-gears.

The other features of my invention appear hereinafter in the specification and claims.

In the accompanying drawings illustrating my invention A is the boiler, A' the tank and fuel box, B the cylinder, C C' the wheels supporting the boiler mounted in a truck frame B' connected to the engine frame or platform D in the usual manner, and E, E' connecting rods communicating with the cylinder B in the usual manner, all of which parts are of

usual and ordinary construction. The platform under the fuel box and tank A' is supported on a truck frame F, which is connected thereto by means of an ordinary king-bolt (not shown) in the usual manner, so that it will turn thereon in conforming to the curves of the track. This platform D' is made considerably wider than the platform or frame D, supporting the boiler, which only covers the space between the wheels C C' upon which it is supported; the rear end G of the platform D being made in the shape of an arc of a circle, the radius of which is equal to half the length of the axles of the wheels C C' under the platform D. The tender platform D' is also extended forward to a point somewhat beyond the rear end of the boiler and has its central portion cut away to conform to the rear end G of the platform D. Upon this forwardly projecting portion of the platform D' the cab F' is secured. Under the platform D' and firmly bolted thereto, is a strong draw-bar H, which extends forward under the rear end G of the platform D to a king-bolt G', which is the center of the circular portion G of the platform D. Immediately at the rear end of the boiler A, is a transverse shaft H' secured in bearings  $h h$  thereon, the ends of which shaft are provided with rollers I, I, which operate in circular slots I' I' in the projecting portions  $d d$  of the tender platform D', this allowing the tender platform D' to turn freely around the circular portion G of the boiler platform D' a sufficient distance to provide for curves in the track.

Upon the axles J and J' of the wheels C and C' and the axles K K' of the wheels L, L, under the tender, I secure cross-boxes, (shown in dotted lines) adapted to support a longitudinal driving shaft L'. The axles J, K and K' are also provided with skew-gear wheels M, M, M (shown in dotted lines), which intermesh with like sized skew-gear wheels M', M', M', (shown in dotted lines) secured to the longitudinal driving shaft L'. The cross-boxes supporting the said shaft L' on the axles J, K and K', I construct in three sections, the central sections N of which are each provided with half boxes  $n n'$  at right angles to each other the parts  $n$  fitting the under side of the axle, and the parts  $n'$  the upper side of the

shaft L'. These sections N are circular in shape and the half boxes *n* and *n'* extend to both ends of the hub of each gear wheel, so that the gear wheels M and M' are held firmly into mesh with each other. To these central sections N are firmly bolted a half globular upper section O having half boxes *o o* therein fitting over the axle, and together with the half boxes *n* completing the boxes on the axle. There is also firmly bolted to these central sections N a half globular lower section P, which is provided with half boxes *p p* fitting up under the shaft L, and together with the half boxes *n'* completing the boxes on the shaft L. These sections O and P also form a complete inclosure for the skew-gear wheels M and M' and effectually protect them from dust and dirt and at the same time operate as receptacles for retaining lubricants therefor. The shaft L' is also supported by an ordinary cross-box R mounted on the axle J' and by a supporting bracket R' secured to and projecting downward from the portion G of the boiler platform D. The shaft L' is also provided with universal joints S and S' between the truck F and the truck B', and also with an ordinary socket joint T to provide for the elongation thereof, when the locomotive is running around curves in the track. Having thus fully described my invention, so as to enable others to construct and operate it, what I claim as new, and desire to secure by Letters Patent of the United States, is—

1. The combination in a tramway locomotive, of wheels under the boiler driven by a

crank and connecting rod mechanism, with a truck under the tender, a longitudinal driving shaft, cross-boxes on the axles supporting said driving shaft, skew-gear wheels on one of the forward axles intermeshing with equal sized skew-gear wheels on said driving shaft, like skew-gear wheels on said driving shaft intermeshing with equal sized skew-gears on the axles of the wheels under the tender, and universal joints in said shaft, substantially as described.

2. The combination in a skew-gear cross-box, of a central section having half axle bearings in one side thereof, and half shaft bearings in the opposite side thereof at right angles to said half axle bearings, with upper and lower sections having half axle and shaft bearings therein, substantially as set forth.

3. The combination in a skew-gear cross-box, of a central section having half axle-boxes in one side thereof, and half shaft-boxes in the opposite side thereof at right angles to the said half axle-boxes therein, with upper and lower sections having half axle and shaft boxes therein, and shells on said upper and lower sections inclosing the skew-gear wheels mounted on the axle and shaft operating in the boxes therein, substantially as and for the purpose set forth.

In testimony whereof I affix my signature in presence of two witnesses.

CHARLES D. SCOTT.

Witnesses:

F. EINFELDT,  
H. J. CURTZE.