

(No Model.)

3 Sheets—Sheet 1.

G. D. GILBERT.

PROPELLING GEAR FOR TRAM CARS.

No. 393,896.

Patented Dec. 4, 1888.

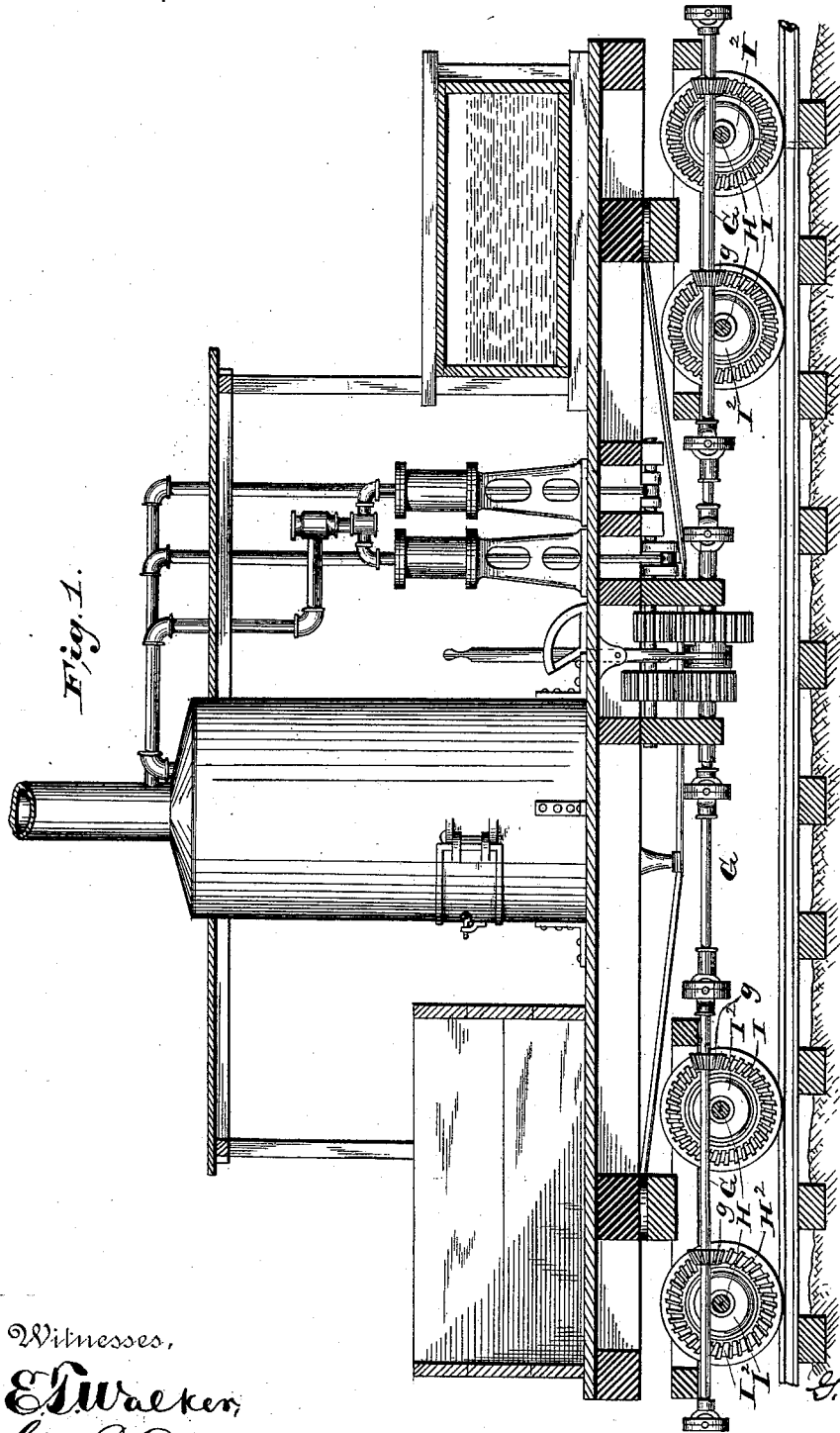

Fig. 1.

Witnesses,

E. Walker,
Chas. D. Lechner,

Inventor,

G. D. Gilbert,

By his Attorneys

Hallock & Hallack

(No Model.)

3 Sheets—Sheet 2.

G. D. GILBERT.

PROPELLING GEAR FOR TRAM CARS.

No. 393,896.

Patented Dec. 4, 1888.

Fig. 2.

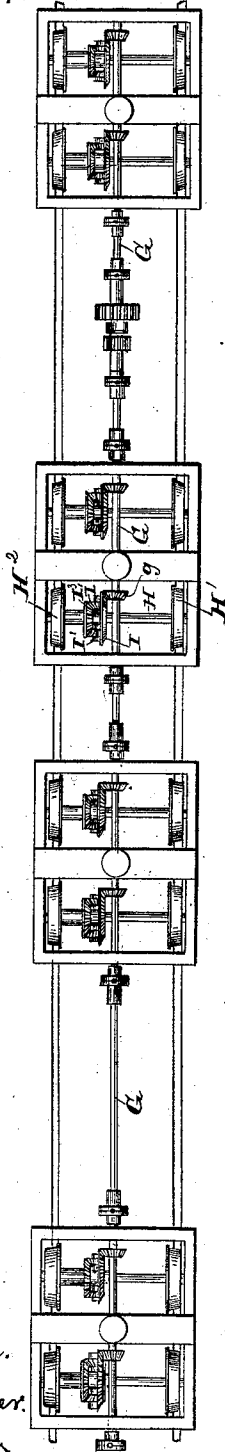
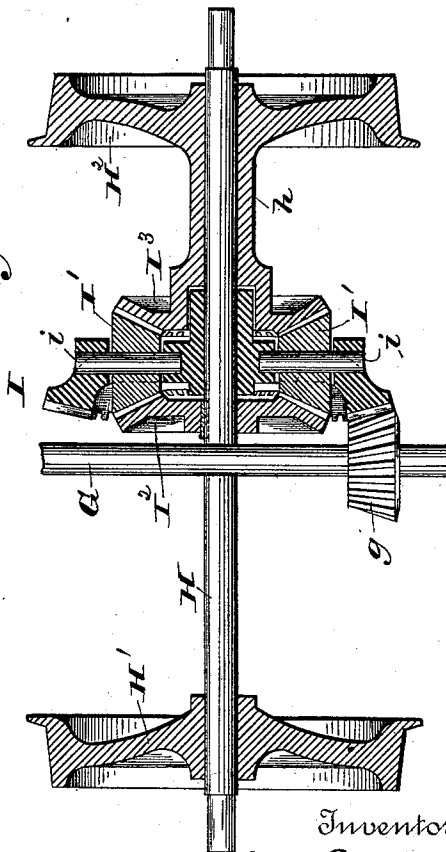

Fig. 3.



Witnesses.
E. Waeker.
Chas. H. Schreyer

Inventor.
G. D. Gilbert.

By his Attorneys
Halleck & Halleck.

(No Model.)

3 Sheets—Sheet 3.

G. D. GILBERT.

PROPELLING GEAR FOR TRAM CARS.

No. 393,896.

Patented Dec. 4, 1888.

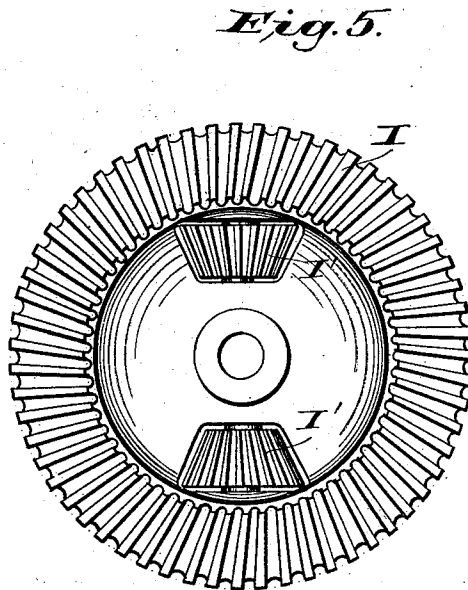
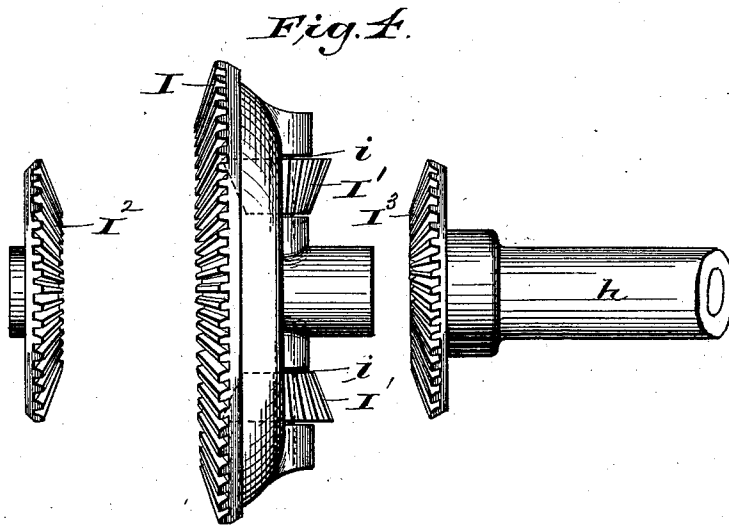

Witnesses,
E. Walker,
Chas. B. Lechner,

Inventor,
G. D. Gilbert,

By his Attorney
Hallock & Hallack,

UNITED STATES PATENT OFFICE.

GEORGE D. GILBERT, OF CORRY, PENNSYLVANIA.

PROPELLING-GEAR FOR TRAM-CARS.

SPECIFICATION forming part of Letters Patent No. 393,896, dated December 4, 1888.

Application filed February 10, 1888. Serial No. 263,620. (No model.)

To all whom it may concern:

Be it known that I, GEORGE D. GILBERT, a citizen of the United States, residing at Corry, in the county of Erie and State of Pennsylvania, have invented certain new and useful Improvements in Propelling-Gearing for Tramway-Cars; and I do hereby declare the following to be a full, clear, and exact description of the invention, such as will enable others skilled in the art to which it appertains to make and use the same.

This invention relates to tramway cars and locomotives; and it consists in certain improvements in the construction of the same, as will be hereinafter fully set forth, and pointed out in the claim.

My invention has for its general object the production of a car or locomotive adapted for use on fragile tramways and on tramways of severe grades. My invention may be applied to the locomotive alone, or to both the locomotive and the cars.

The special object of my invention is to construct a car or locomotive having all its wheels free to move independently and all propelled from a common longitudinal shaft.

I am aware that it has been common to make the wheels of locomotives so that each wheel had independent action and independent propulsion; but I am not aware that this has been done in connection with mechanism for giving all the wheels in a locomotive or car, or a whole train of cars, independent propulsion, which is what I do and what constitutes the essential purpose of my invention.

My invention is illustrated in the accompanying drawings as follows:

Figure 1 is a longitudinal vertical section through a locomotive or motor-car constructed in accordance with my invention, the boiler and engine being left in elevation, as are also some of the minor central parts. Fig. 2 is a top view of the running-gear of the motor-car shown in Fig. 1 and another car attached thereto. Fig. 3 shows two opposite wheels of a car in horizontal section, the axle on which they run in elevation, the main driving-shaft in elevation, and most of the gearing in horizontal section. Fig. 4 is an elevation view of the several parts of the gearing which is on the car-axles, looking at right angles to the axle. Fig. 5 is an elevation view of the great

skew gear-wheel I, looking in line with the axle.

The general construction of the locomotive or motor-car here shown needs no description.

So far as the application of my invention is concerned, it makes no difference whether the car is a motor-car or not, for each car, whether the main shaft is propelled by a motor on that car or on some other car, will have upon it all the elements of my device, and these will be repeated as many times on a car as there are pairs of wheels geared to be operated from the main shaft. All the elements of my device are therefore found in Fig. 3, and to understand the following description there will be little need of reference to any other figure.

H is one of the car-axles. H' is a car-wheel at one end of said axle, and H² a like wheel at the other end thereof. The wheel H' is fixed to the axle, while the wheel H² is loose upon the axle. Near the central part of the axle there is a beveled pinion, I², fixed to the axle, and facing it is a companion pinion, I³, loose on the axle. The loose pinion I³ and the loose car-wheel H² are connected by a sleeve, h. Between the pinions I² and I³ there is loosely journaled on the axle a large beveled pinion, I, which carries in its web one or more beveled pinions, I', the journals i of which are radial to the pinion I. These pinions I' mesh with the pinions I² and I³. This train of gearing—to wit, I, I', I², and I³—is well understood by mechanics, and is often called "differential gearing."

G is a main shaft passing over and at right angles to the axles, and on it is a beveled gear, g, which meshes with the main driving-gear I.

The gears I and g are cut skew. This is necessary to enable me to use a continuous shaft in combination with a series of differential gears, as shown. Heretofore where differential gears have been used on locomotives the shaft has not been continuous over a series of axles.

It is not necessary to explain the operation of the gearing shown, as it is all well known to mechanics. It is plain, however, that both wheels H' and H² will be propelled from a rotation of the shaft G, and also that either

- wheel may be at rest and the other in motion, and that when one is at rest the motion of the other is twice as great as when both are in motion. It will therefore be seen that, for example, the wheel II' may stand still on the inner rail of a sharply-curved track, and the wheel II^2 will receive the additional momentum necessary to carry it over the outer rail without sliding upon it.
- 10 It will be seen that a car provided with my invention can be run on roads having very short curves and not have its wheels slide upon and destroy the track, which is extremely desirable where the track is made of wood.
- 15 A train of cars constructed as shown in Fig. 2 can climb very steep grades and wind along a very serpentine track—a thing very

desirable in mountainous or heavily-wooded countries.

What I claim as new is—

In a tramway car or locomotive, the combination, with a car-axle having thereon a fixed wheel at one end and a loose wheel at the other end, and a driving-shaft crossing said axle at right angles, of the differential gear $I' I^2 I^3$ on said axle, and a skew-cut beveled pinion, g , on said driving-shaft meshing with skew-cut beveled gear-teeth on the pinion I .

In testimony whereof I affix my signature in presence of two witnesses.

GEO. D. GILBERT.

Witnesses:

JNO. K. HALLOCK,

E. T. WALKER.