

(No Model.)

6 Sheets—Sheet 1.

C. L. HEISLER.  
LOCOMOTIVE.

No. 585,031.

Patented June 22, 1897.

FIG. 1.

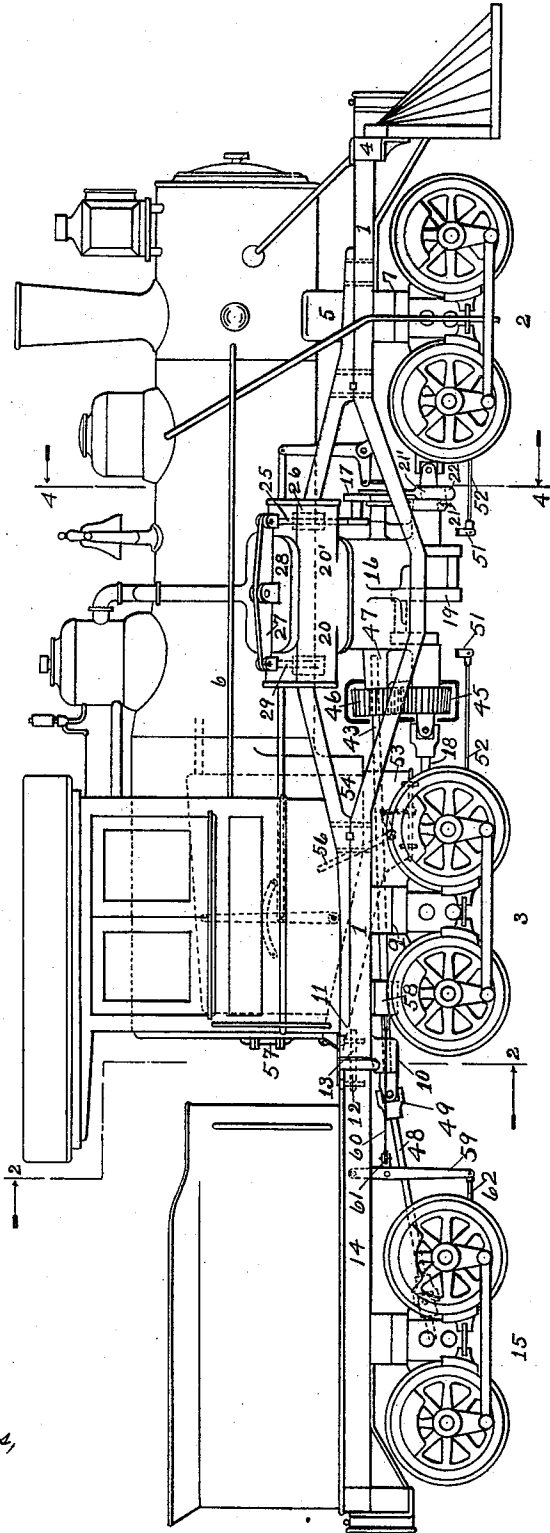

WITNESSES:  
*Chas. Heisler.*  
*L. Adams,*

INVENTOR  
*Chas. L. Heisler.*

(No Model.)

6 Sheets—Sheet 2.

C. L. HEISLER.  
LOCOMOTIVE.

No. 585,031.

Patented June 22, 1897.

Fig. 2.

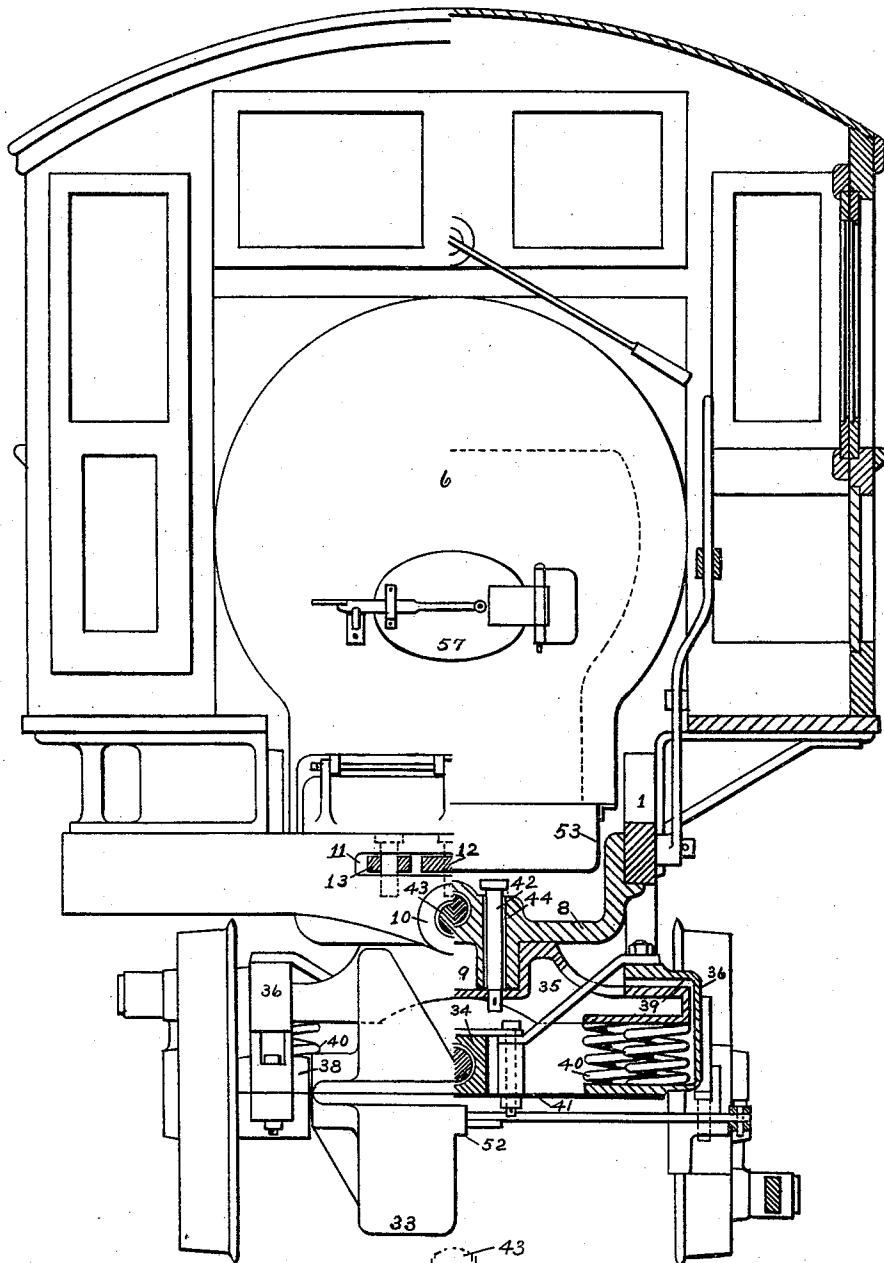

WITNESSES:  
*Chas. Heisler*  
*L. Adams*

Fig. 3.

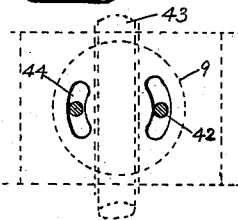

INVENTOR  
*Chas. L. Heisler*

(No Model.)

6 Sheets—Sheet 3.

C. L. HEISLER.  
LOCOMOTIVE.

No. 585,031.

Patented June 22, 1897.

Fig. 4.

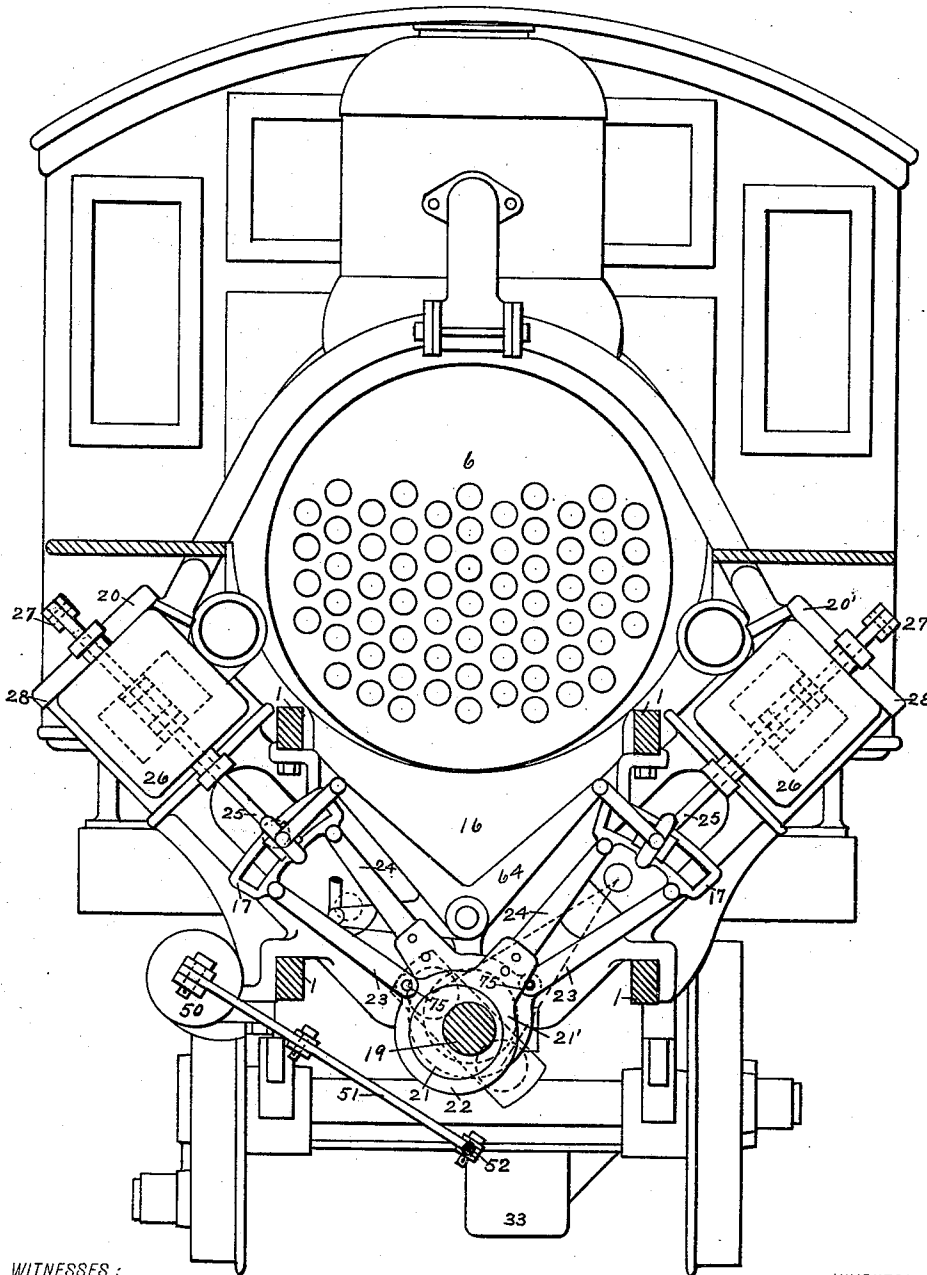

WITNESSES:  
*Wm. Heisler.*  
*B. Adams,*

INVENTOR  
*Chas. L. Heisler*

C. L. HEISLER.  
LOCOMOTIVE.

No. 585,031.

Patented June 22, 1897.

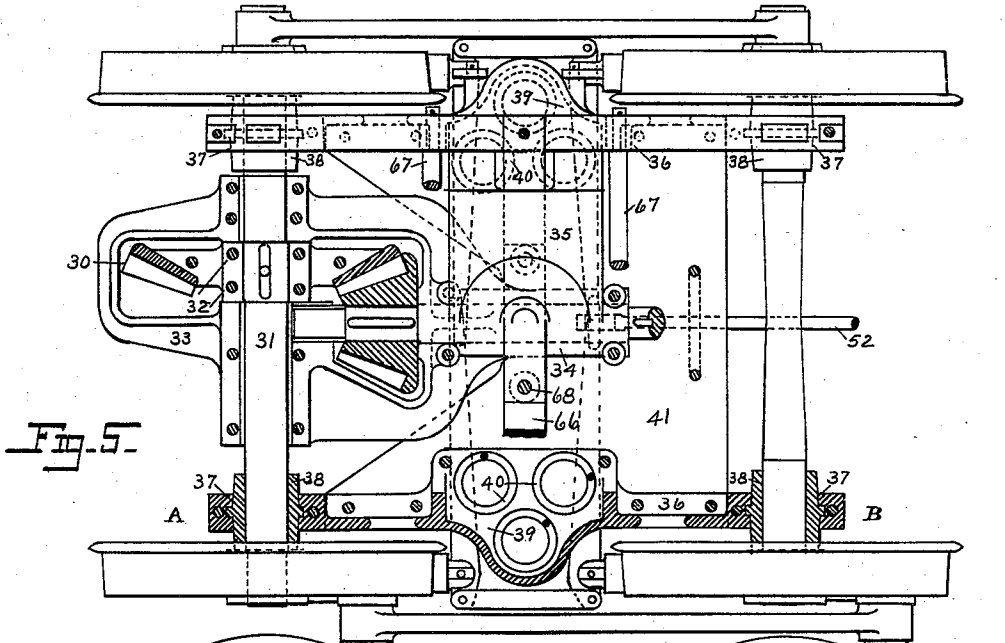

Fig. 5.

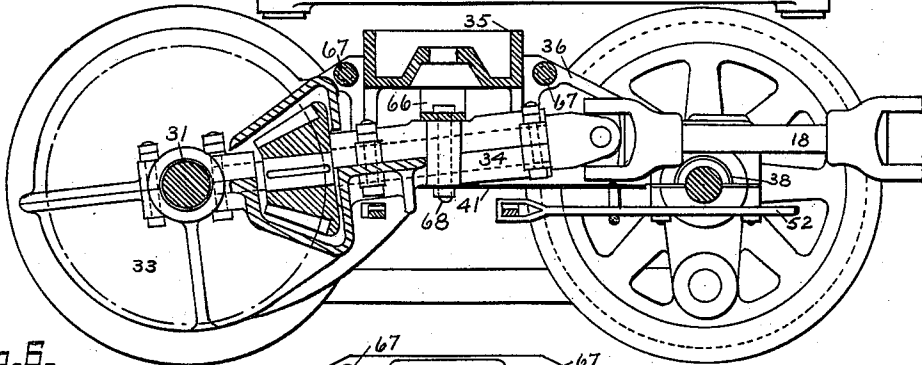

Fig. 6.

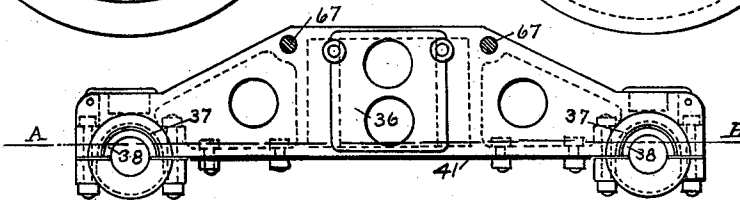

Fig. 7.

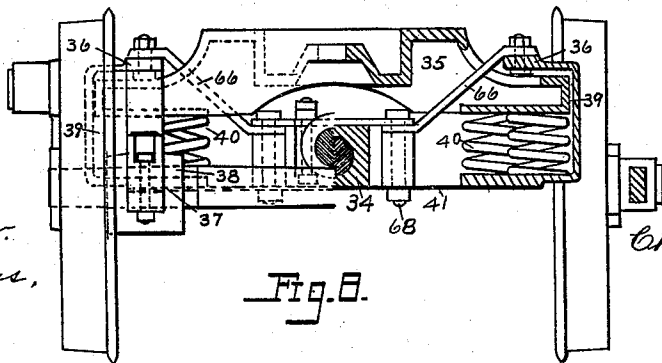

Fig. 8.

WITNESSES:  
*Chas. Heisler.*  
*L. Adams.*

INVENTOR  
*Chas. L. Heisler.*

(No Model.)

6 Sheets—Sheet 5.

C. L. HEISLER.  
LOCOMOTIVE.

No. 585,031.

Patented June 22, 1897.

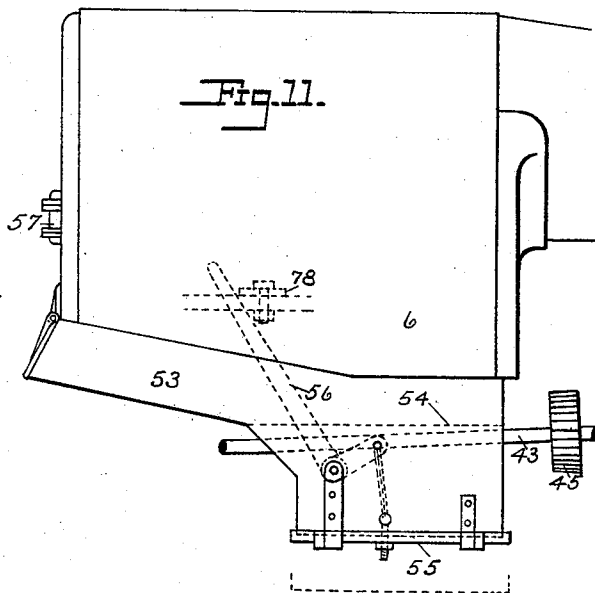
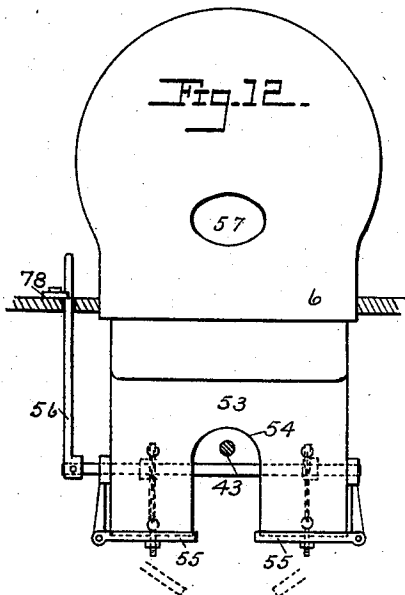
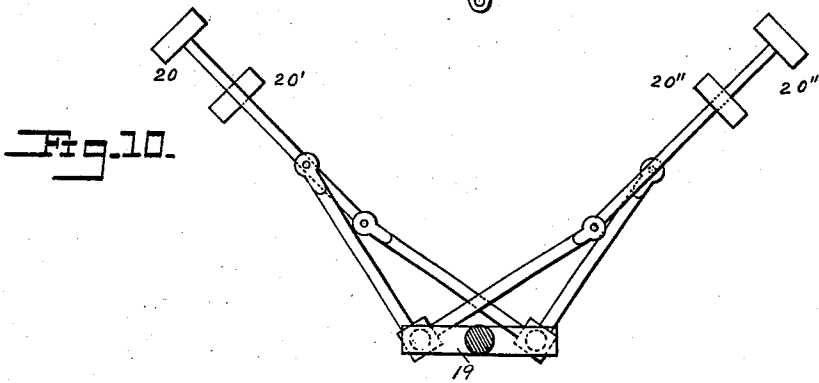
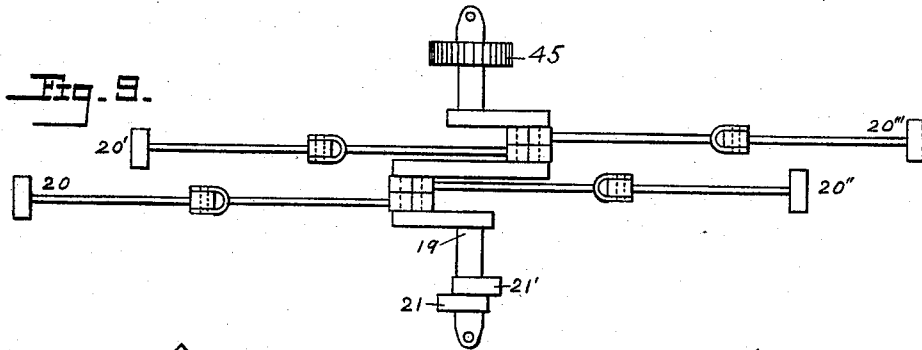

WITNESSES:

*Chas. Heisler.*  
*L. Adams.*

INVENTOR

*Chas. L. Heisler.*

(No Model.)

6 Sheets—Sheet 6.

C. L. HEISLER.  
LOCOMOTIVE.

No. 585,031.

Patented June 22, 1897.

Fig. 13.

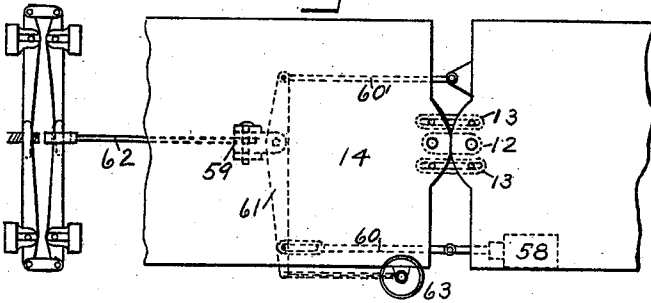

Fig. 14.

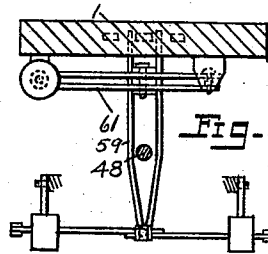
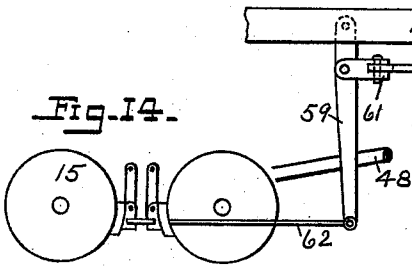

Fig. 15.

Fig. 16.

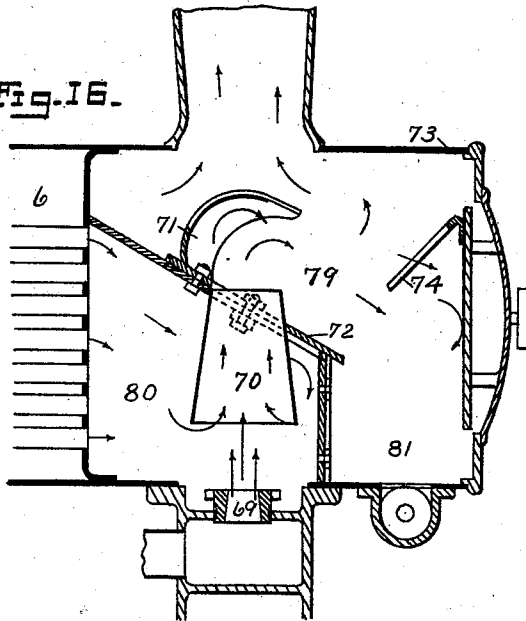
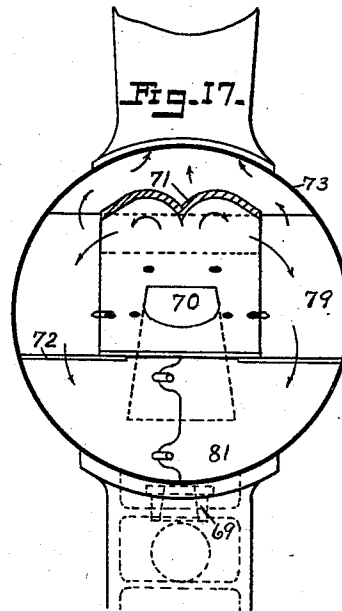

Fig. 17.



WITNESSES:

*Wm. Heisler.*  
*L. Adams,*

INVENTOR

*Chas. L. Heisler,*

# UNITED STATES PATENT OFFICE.

CHARLES L. HEISLER, OF PHILADELPHIA, PENNSYLVANIA.

## LOCOMOTIVE.

SPECIFICATION forming part of Letters Patent No. 585,031, dated June 22, 1897.

Application filed November 26, 1894. Serial No. 529,997. (No model.)

*To all whom it may concern:*

Be it known that I, CHARLES L. HEISLER, a citizen of the United States, residing at Philadelphia, Philadelphia county, State of Pennsylvania, have invented certain new and useful Improvements in Locomotives, of which the following is a specification.

My invention relates to locomotives requiring great tractive power at moderate speed, for use in connection with roads having steep grades, sharp curves, and which are liable to have a very uneven road-bed; and my invention consists of special features and construction hereinafter pointed out.

Referring to the accompanying drawings, Figure 1 is a side view of a locomotive embodying my invention. Fig. 2 is a vertical cross-section at the rear of cab and middle of intermediate truck. Fig. 3 is a plan of circular king-bolt slots in foot-plate. Fig. 4 is a vertical cross-section in front of the dome, looking rearward. Fig. 5 is a plan of one of the trucks. Fig. 6 is a longitudinal section of the truck. Fig. 7 is a side view of the truck-frame. Fig. 8 is an end view thereof. Fig. 9 is a skeleton of the double crank, showing the manner of connecting the cylinders. Fig. 10 is a side view of the double crank. Fig. 11 is a side view of ash-pan. Fig. 12 is an end view thereof. Fig. 13 is a plan of tender-brake rig. Fig. 14 is a side view thereof. Fig. 15 is an end view thereof. Fig. 16 is a side view of the spark-arrester. Fig. 17 is an end view thereof.

In Letters Patent of the United States No. 482,828, issued to me September 20, 1892, I show, describe, and claim several features common to the locomotive herein specified, so that my present invention principally embodies improvements and enlargements made upon the invention covered by the aforesaid Letters Patent.

To obtain great strength, lightness, simplicity, and to make the mechanism of the locomotive readily accessible, the main frame 1 is constructed of a pair of diamond-shaped side frames extending over the front and intermediate trucks 2 and 3. The side frames are connected at the front end by the usual cross-timber 4, and a saddle-casting 5, forming a support for the locomotive-boiler 6, and a pivot 7 for the front truck. At the back

end the side frames are connected by a heavy foot-plate 8, which forms a pivot 9 for the intermediate truck, also a shaft-bearing 10 and a pocket 11 for the heavy main link 12 and the two safety slotted links 13, which form a flexible connection between the main frame 1 and the tender-frame 14. The tender-frame is of the usual construction, carrying the tank and fuel, being pivotally mounted upon the back truck 15.

The boiler 6 is of the horizontal locomotive type, having a fire-box at the rear end, and which projects below the cylindrical shell thereof. The boiler is supported at the front end by the frame-saddle 5 and at the back end by suitable expansion-links in the usual manner. To avoid excessive heat and smoke in the cab from the fire-door 57, the jacketed boiler is made to extend entirely through the cab, so that the fire-door is outside and to the rear thereof. This arrangement permits the use of a much larger boiler without increasing the length of the main frame. This is an important feature, since the total length of the locomotive must be a minimum in order to readily pass the sharp curves. Moreover, because of the heavy duty required of these engines on mountain work the boiler's capacity must be a maximum. I do not broadly claim this arrangement of boiler and cab, but limit myself to its combination with the type of locomotive having a centrally-located longitudinal driving-shaft and that is mounted upon swiveling geared trucks.

The motor-engines 20 20' 20'' 20''' are mounted upon the main frame and essentially located under the cylindrical end of the boiler, between the fire-box and forward truck, as shown by Fig. 1, thus making it possible to obtain a deep and large fire-box, with ample space for ashes under the grates. This arrangement permits the use of a much larger boiler, thereby greatly increasing the power of the locomotive; moreover, makes possible a more uniform distribution of weights upon the trucks. Heretofore in locomotives of this type having a central longitudinal driving-shaft but two cylinder motor-engines were used and they were connected to a single crank. For the heavy locomotives it is necessary to have far greater cylinder-power in order to slip twelve drivers under the three

driving-trucks shown in Fig. 1: Therefore one of the objects of my invention consists in providing a multicylinder motor-engine 16, connected to a central longitudinal propelling-shaft 18; furthermore, one which would be in essentially good balance when running at the high speed necessary to obtain the requisite power. To accomplish these results, a double-crank motor-shaft 19 is substituted for the single crank formerly used. The cranks are arranged so as to be diametrically opposite and near each other. Then by using four motor-cylinders 20 20' 20'' 20''' and connecting them to the motor-shaft 19, as shown in Fig. 9, the reciprocating parts of either adjacent pair of engines, 20 and 20' or 20'' and 20''', continually move in opposite directions, thereby balancing their reciprocating parts and permitting a high speed without vibration, a feature highly essential to the successful running and life of the locomotive.

Instead of providing for the four cylinders two sets of valve-gears having two pairs of reversing-trucks, I use eight eccentrics, with their complements of straps and rods, and another important feature of my invention is the material reduction of the number of parts necessary to operate the four valves, thus lessening the complication and effecting a great saving in first cost and expense of maintenance. To accomplish this, the pair of eccentrics 21 21' is mounted at one end of the motor-shaft, and each eccentric is fitted with a strap 22, having two rods 23 and 24 attached thereto. One rod, 23, is pivotally connected at 75 and the other, 24, rigidly connected to prevent the strap from revolving with the eccentric. The rods make the same angle with each other as the engines and connect to their corresponding links 17 in the usual manner. From the links the motion is transmitted to the engine-valves through a suitable valve-stem 25, which is extended through the steam-chest 26 and pivotally connected to a rocking lever 27, mounted upon the cylinder-covers 28. The rocking lever transmits the reciprocating motion of the valve and valve-stem 25 to the corresponding valve-stem 29 and valve of the adjacent cylinder. The valves are of the common **D** pattern and are balanced to insure their light running.

I do not wish to limit myself to the particular location of the rocking lever 27, as it may be placed in different positions and accomplish the same results. This position is chosen because of its accessibility.

The locomotive is provided with three trucks, each having two pairs of drivers connected by side rods in the customary manner. To facilitate making repairs without the use of skill and special tools and when in use in places remote from workshops, the bevel-gear 30 is removably fastened to the enlarged driving-axle 31 farthest from the motor-engines by means of the clamp-bolts 32, thus avoiding the necessity of removing the driving-wheels when replacing the gears.

To prevent any abnormal strain due to the action of the gears from coming upon the truck-frame, the gears and their shaft-bearings are mounted upon a separate and self-contained inclosing gear-frame 33, which is hinged upon the enlarged axle with its pinion-shaft end 34 resting upon the truck-frame directly under the bolster 35. This arrangement permits the driving-axle to accommodate itself to the uneven track without affecting the accurate alinement of the gears. Moreover, the gear-frame forms a protection to the gears inclosed thereby. It is essential in these locomotives to provide the simplest construction. Therefore the side frames 36 of the truck are each made of a single steel casting which has suitable semicircular recesses 37 in the ends for retaining the axle-brasses 38. At the middle of each frame a rectangular housing 39 is provided for the coil-springs 40, that support the truck-bolster 35, the end of which slidingly fits the rectangular housing of each side frame. The lower edge of each side frame is in line with the center of the semicircular recesses 37. This is very desirable, because the two frames can be bolted together and the recesses bored at one setting, thus reducing the cost of machining one-half. The side frames are fastened at their lower edge to a thin and flexible bottom plate 41, which permits the truck to adjust itself to the uneven track, but prevents it getting out of square when meeting obstructions and passing curves. The cross-strut 42 and the diagonal brace 66 resist the side-sway of the locomotive. Moreover, the brace with the bolts 68 and bottom plate 41 form a housing for the pinion-shaft end of the gear-frame 33. The intermediate truck is fitted with two king-bolts, one on each side of the central shaft 43. In the foot-plate 8 are circular slots 44, so the truck may swing about its center without cramping the king-bolts.

The double-crank motor-shaft 19, fixed upon the motor-engine 16, is connected to the front and intermediate trucks 2 and 3 by the intervention of floating-shafts 18 and knuckles in the usual manner. The rear or tender truck 15 is driven independently from the motor-shaft by the second shaft 43 and two gears 45 and 46, one fixed to the motor-shaft and the other to the fixed section of the second shaft. This construction avoids the double duty that otherwise would come upon the connections if both trucks were driven by a single main shaft, as has been the practice heretofore. One bearing, 47, of the fixed section of the second shaft is preferably located upon the motor-engines, the other, 10, upon the foot-plate 8. To reduce the angular movement of the floating-shaft 48, connecting the fixed section with the pinion-shaft upon the truck, it is best to locate the knuckle-joint 49 under the hinge or link coupling 12 between the main frame and tender-frame. The second shaft passes centrally



over and between the two king-bolts of the intermediate truck.

The brake-cylinder 50 is of the usual construction, and for simplicity and ready access is mounted under the motor-engines, as shown in Figs. 1 and 4, the brake-levers 51 reaching from the cylinder to the central rods 52, connected with the truck, and which run parallel with the track, being situated directly under the central driving-shaft. By this arrangement they are accessible, clear of obstructions, and do not loosen or tighten on curves, since they draw directly from the truck-center.

The ash-pan 53 is fitted with an arch 54 in the bottom to clear the central shaft. On each side of the arch is arranged a suitable drop-door 53, provided with hinges and levers 56 for the purpose of operating them from the cab, if desired, the lever being locked by means of a latch 78. Evidently this device saves the laborious cleaning of the ash-pan by washing and scraping, as is common practice.

Fig. 13 shows the rear-truck brake device, which permits a free movement of the tender and trucks on sharp curves and uneven tracks without affecting the tension upon the brake-shoes or causing unnecessary movement of the brake-lever system. The brake-cylinder 58 is mounted upon the main frame 1 so its pivoted connection with one of the parallel rods 60' is opposite the link 12, connecting the tender-frame with the main frame. The end of the parallel rod 60 is pivoted to the main frame so the link is in line with the ends of both rods. The rods are also connected with a compensating bar 61. This bar is connected to an upright lever 59. The upright lever is pivoted at one end to the tender-frame. At the other end it is attached to a centrally-located brake-rod 62, operating the truck-brakes in the usual manner. Evidently any pull applied to one of the parallel rods is transmitted to the brake-rod 62, whatever the angular movement of the tender-frame. Furthermore, since a line drawn through the ends of the parallel rods 60 and 60' and the link 12 is practically parallel with the bar 61, thus the whole forms a parallelogram. Therefore the angular movement of the tender-frame about the link 12 as a center will not appreciably affect either the upright lever 59 or the brake-cylinder piston. The same results are obtained whether or not the rods 60 and 60' are on opposite sides of the link 12, so long as the parallelogram is not eliminated. If desired, the hand-brake 63 can be attached to the bar 61 and the rod 60' can be slotted to permit an independent action of the hand-brake.

These locomotives being extensively used in heavy timber, it is essential that sparks must not escape from the stack. For this purpose the cylindrical boiler-shell 73 is extended to provide extra room in the smoke-box 79, as shown in Figs. 16 and 17. The ex-

haust-nozzle 69 is situated at the lower side of the smoke-box, and directly over it is a short tube 70, which is provided with a suitable hood 71. The smoke-box is divided into two sections 80 and 81 by the removable partition 72. The exhaust-steam forces the products of combustion through the tube and against the hood, which deflects the current and causes the sparks or cinders to lodge in the pocket 81. The grating 74 prevents the current in its passage to the stack from lifting the cinders out of the pocket. Any suitable means may be provided for removing the accumulated cinders from the device.

What I claim is—

1. In a locomotive, the combination of a diamond-shaped main frame, trucks supporting each end thereof, and a centrally-located longitudinal driving-shaft connecting the trucks, substantially as described.

2. In a locomotive, the combination of a diamond-shaped main frame, trucks supporting each end thereof, engines mounted thereon, and arranged with their center lines at an angle to each other, and so that they project through the openings between the upper and lower members of the diamond main frame, substantially as described.

3. In a locomotive, the combination of a diamond main frame, swiveling trucks supporting the ends thereof, a tender-frame mounted upon a separate truck, and hinge-like connections between said latter truck and the main frame, substantially as described.

4. In a locomotive, the combination of a main frame, a swiveling truck at each end of the main frame, a boiler resting upon the frame, a centrally-located longitudinal shaft, motor-engines arranged at an angle to each other, and located essentially beneath the boiler but separate therefrom, and secured to the main frame, the said boiler being arranged within the angle and passing through the plane of the angle with its axis perpendicular to said plane, substantially as described.

5. In a locomotive, the combination of a truck at each end of a main frame, a centrally-located longitudinal shaft connecting the pair of trucks, a second central shaft driving the tender or rear truck, a foot-plate connecting the back end of the main frame, and pivotally connected to the intermediate truck, forming a support for the fixed section of the second shaft, substantially as described.

6. In a locomotive mounted upon trucks, and having a centrally-located shaft connecting the trucks, the combination of diamond-shaped longitudinal main frames supported by the trucks, and motor-engines mounted in and projecting through the openings in the frames at an angle to each other, and having more than two cylinders acting upon a double-throw crank-shaft, substantially as described.

7. In a locomotive mounted upon trucks, and having a centrally-located shaft connecting the trucks, the combination of diamond-

- shaped longitudinal main frames supported by the trucks, and three or more engines mounted in and projecting through the openings in the frames at an angle to each other, and connected to a double-throw crank-shaft, the said engines having the eccentrics of the necessary valve-gear located at one side of the double crank, substantially as described.
8. In a locomotive, the combination of longitudinal diamond-shaped main frames, a truck at each end thereof, a centrally-located longitudinal shaft connecting the trucks, motor-engines mounted in and projecting through the openings in the frames at an angle to each other, and connected to a double-crank shaft, and a tumbling-shaft common to all the engines, arranged within the angle formed by the engines, substantially as described.
9. In a locomotive, the combination of longitudinal diamond-shaped main frames, a truck at each end thereof, a centrally-located longitudinal shaft connecting the trucks, motor-engines mounted in and projecting through the openings in the frames at an angle to each other, and connected to a double-crank shaft, the eccentrics connected to the shaft at one side of the double crank, and the tumbling-shaft common to all the engines arranged within the angle formed by the engines, substantially as described.
10. In a locomotive, mounted upon trucks and having a centrally-located longitudinal shaft connecting the trucks, the combination of engines arranged at an angle to each other, a rocking lever connected to the valve-movement of one cylinder, and actuating the valve of the adjacent cylinder, substantially as described.
11. In a locomotive, mounted upon trucks and having a centrally-located longitudinal shaft connecting the trucks, the combination of engines arranged at an angle to each other, a rocking lever connected to the valve-movement of one cylinder, and actuating the valve of the adjacent cylinder, and the eccentrics of the entire valve-gear located at one side of the cranks, substantially as described.
12. In a locomotive, the combination of a truck at each end of a main frame, a centrally-located longitudinal shaft connecting the trucks, engines arranged at an angle to each other and connected to the central shaft, a pair of eccentrics, the straps of each having two rods, making an angle to each other, one pivotally attached to the strap, and the other rigidly fixed to said strap, and each connected with its corresponding link, substantially as described.
13. In a locomotive, the combination of a truck at each end of the main frame, a centrally-located longitudinal shaft connecting the trucks; a boiler supported by the main frame, and having a fire-box projecting below the cylindrical shell thereof; motor-engines mounted upon the main frame, and making an angle with each other, and connected to the central motor-shaft, and placed under the cylindrical shell and between the projecting fire-box and forward truck, substantially as described.
14. In a locomotive, mounted upon trucks, and having a centrally-located longitudinal shaft connecting the trucks, the combination with the truck, of a metallic side frame, made in one piece, fitted with recesses at the ends for receiving the axle-brasses, a housing at the middle, springs resting within the housing and supporting one end of a cross-bolster slidingly fitted between the end walls of the housing, substantially as described.
15. In a locomotive, mounted upon trucks and having a centrally-located longitudinal shaft connecting the trucks, the combination with the truck, of a metallic side frame made in one piece, the semicircular recesses at each end of the frame, the lower edge of said frame being in line with the center of the recesses, substantially as described.
16. In a locomotive mounted upon trucks, and having a centrally-located longitudinal driving-shaft connecting the trucks, the combination with the truck, of a side frame made in one piece, axle-brasses in the ends thereof, a cross-bolster mounted upon springs, a thin flexible bottom plate connecting the pair of frames, diagonal braces fastened to the thin flexible bottom and side frames, and cross-struts at the top, substantially as described.
17. In a locomotive, mounted upon trucks and having a centrally-located longitudinal driving-shaft, connecting the trucks, the combination with the truck of a gear-frame hinged upon the axle, and one end resting upon the bottom truck-plate, and fastened thereto by suitable means, substantially as described.
18. In a locomotive, the combination of longitudinal diamond-shaped main frames, a pivoted truck at each end thereof, motor-engines mounted in and projecting through the openings in the frames at an angle to each other, a centrally-located longitudinal driving-shaft connecting the trucks, universal couplings joining the shaft-sections, and gears having a beveled face and removably clamped to the truck-axles, substantially as described.
19. In a locomotive, the combination of longitudinal diamond-shaped main frames, a pivoted truck at each end thereof, motor-engines mounted in and projecting through the openings in the frames at an angle to each other, a centrally-located longitudinal driving-shaft connecting the trucks, universal couplings joining the shaft-sections, gears having a beveled face, and removably clamped to the truck-axles, and a self-contained inclosing gear-frame for maintaining alinement of said gears, substantially as described.
20. In a locomotive, the combination of longitudinal diamond-shaped main frames, a pivoted frame at each end thereof, motor-engines mounted in and projecting through the openings in the frames at an angle to each

other, a centrally-located longitudinal shaft connecting the trucks, universal couplings joining the shaft-sections, gears having a beveled face and removably clamped to the truck-axles, and a tender-frame hinged to the main frame and mounted upon a single truck driven from the central shaft, substantially as described.

21. In a locomotive, the combination of longitudinal diamond-shaped main frames, a pivoted truck at each end thereof, motor-engines mounted in and projecting through the openings in the frame at an angle to each other, a centrally-located longitudinal shaft connecting the trucks, universal couplings joining the shaft-sections, gears having a beveled face and removably clamped to the truck-axles, and a tender-frame hinged to the main frame and mounted upon a single truck driven from the central shaft, which are maintained in alinement by an inclosing and self-contained gear-frame, substantially as described.

22. In a locomotive, the combination of a truck at each end of the main frame, a central longitudinal shaft connecting the pair of trucks, a tender-frame hinged to the main frame, and mounted upon a rear driving-truck, a separate central shaft, coupling the rear truck directly to the motor-shaft, and so arranged that it is independent of the connections that drive the intermediate truck, substantially as described.

23. In a locomotive, the combination of a swiveled truck at each end of the main frame, an intermediate truck a central motor-shaft, a gear mounted thereon, and meshing with a gear fastened to the second shaft, and so arranged as to drive the rear truck, independent of the intermediate truck, substantially as described.

24. In a locomotive, the combination of a truck at each end of the main frame, a central motor-shaft, a gear mounted thereon, and meshing with a gear fastened to a fixed section of the second shaft, a shaft-section mounted upon the rear truck, and a floating-shaft section, connecting the fixed section of the second shaft, with the section on the rear truck, substantially as described.

25. In a locomotive, the combination of a truck at each end of the main frame, a central motor-shaft, a gear, mounted thereon and meshing with a gear fastened to a fixed section of the second shaft, a shaft-section mounted upon the rear truck, a floating-shaft section interposed between the fixed shaft-section, and the section on the truck, and knuckle-joints connecting the shaft-sections, substantially as described.

26. In a locomotive, the combination of a truck at each end of the main frame, a central motor-shaft connected with the trucks, a second shaft driving the rear truck, and passing centrally over and clear of the intermediate truck, substantially as described.

27. In a locomotive, the combination of a truck at each end of the main frame, a central motor-shaft connected with the trucks, a second shaft driving the rear trucks, and passing over the intermediate truck, which is fitted with two king-bolts, one on each side of the second shaft and arranged to permit free movement of the truck and shaft, substantially as described.

28. In a locomotive, the combination of longitudinal diamond-shaped main frames, a truck at each end thereof, a centrally-located longitudinal shaft, motor-engines mounted in and projecting through the openings in the frames at an angle to each other, a brake-cylinder located under the motor-engines and near the cylinders thereof, suitable levers connecting the brake-cylinder with a centrally-located rod, situated under the central shaft and connecting with suitable brake-levers upon the truck, substantially as described.

29. In a locomotive, the combination of a main frame, a boiler mounted thereon and fitted with a fire-box, an ash-pan, located beneath the fire-box, and arranged with a hinged drop-bottom, a crank-arm provided with a link, connecting it with the hinged bottom, an operative lever forming part of the crank-arm shaft, a latch or stop, for securing the lever when the bottom is in a closed position substantially as described.

30. In a locomotive, the combination of a truck at each end of the main frame, a centrally-located longitudinal driving-shaft, connecting the trucks, a boiler mounted upon the main frame and fitted with a fire-box, an ash-pan located beneath the fire-box, and arranged with a hinged drop-bottom, operated by a lever, substantially as described.

31. In a locomotive, the combination of a truck at each end of the main frame, a centrally-located longitudinal driving-shaft connecting the trucks, a boiler mounted upon the main frame and provided with a fire-box, an ash-pan fitted with an arch so as to clear the central shaft, a hinged drop-bottom on each side of the arch, operated by a suitable lever, substantially as described.

32. In a locomotive, the combination of a main frame 1, a second frame 14 pivotally connected to the main frame, parallel rods 60 and 60', attached to opposite ends of a compensating bar 61, which is attached to a suitable lever mounted upon the second frame and connected with the brakes; the parallel rods terminating on opposite sides of the pivoted connection, one end pivotally attached to the main frame, and the other attached to any suitable power for operating the brakes.

33. In a locomotive, the combination of a main frame 1, a second frame 14, the parallel rods 60 and 60' the compensating bar 61, the upright lever 59 connected to the compensating bar, as shown and described.

34. In a locomotive, the combination of a main frame 1, a second frame 14, the paral-

lel rods 60 and 60' the compensating bar 61 and the brake-cylinder 58 mounted upon the main frame, substantially as described.

35. In a locomotive, the combination of a main frame 1, a second frame 14, the parallel rods 60 and 60', the compensating bar 61 the brake-cylinder 58 mounted upon the main frame; and the hand-brake 63 substantially as described.

36. In a locomotive, the combination of a main frame 1, a second frame 14, the parallel rods 60 and 60', the compensating bar 61, the upright lever 59 and the centrally-located truck-rod 62, as shown and described.

CHARLES L. HEISLER.

Witnesses:

WM. HEISLER,  
A. P. MORRISON.