

No. 870,769.

PATENTED NOV. 12, 1907.

J. E. FRIERMOOD.
LOCOMOTIVE.

APPLICATION FILED JULY 12, 1906.

3 SHEETS—SHEET 1.

Fig. 1.

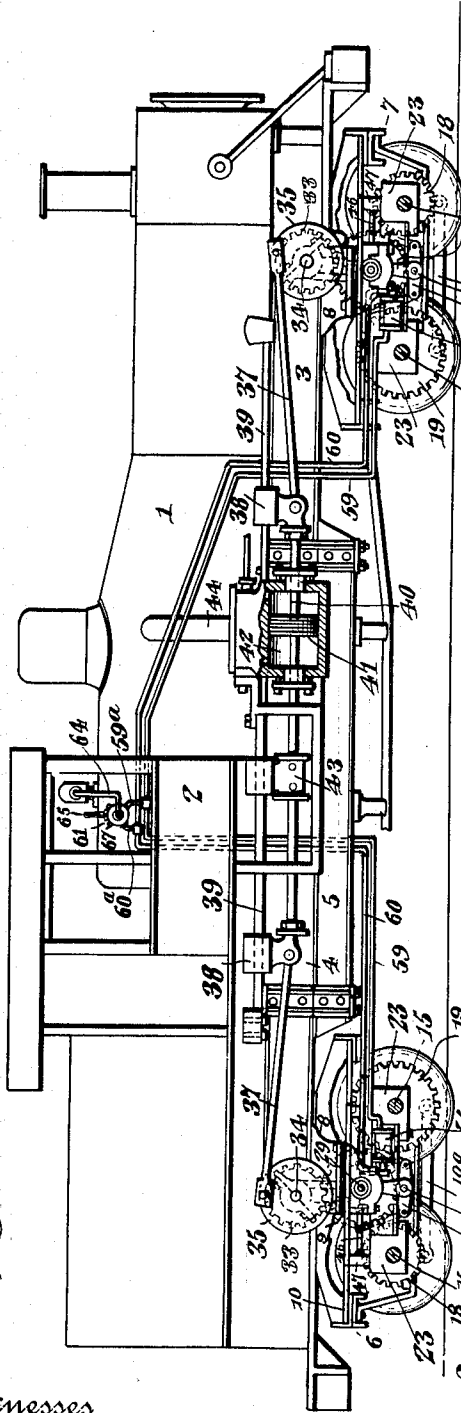

Fig. 8.

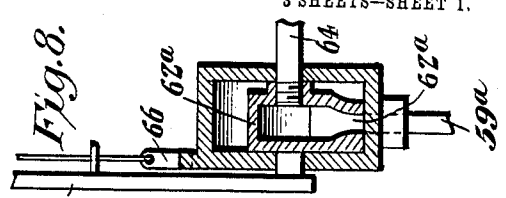

Fig. 7.

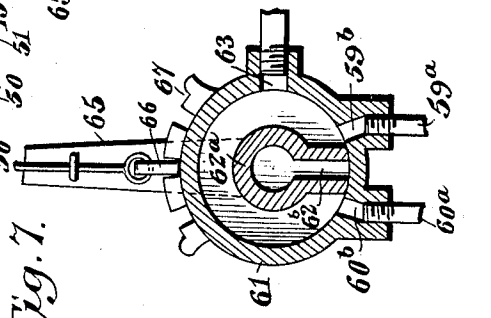
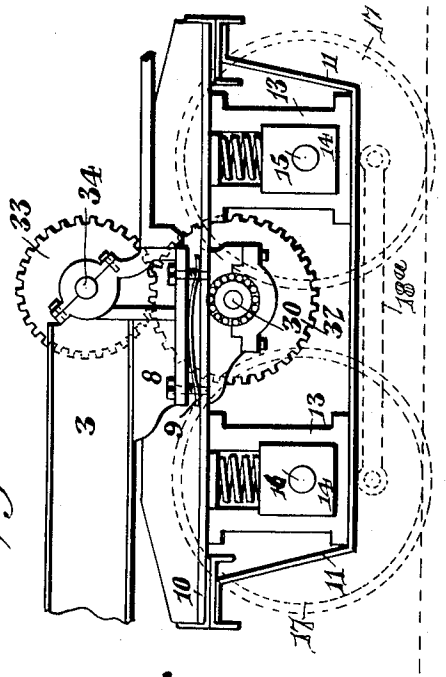

Fig. 2.



Witnesses
Jas. E. McEathran
Lucas G. Julihn

Inventor,
John Earl Friermood.

E. G. Siggers
 Attorney

No. 870,769.

PATENTED NOV. 12, 1907.

J. E. FRIERMOOD.
LOCOMOTIVE.

APPLICATION FILED JULY 12, 1906.

3 SHEETS—SHEET 2.

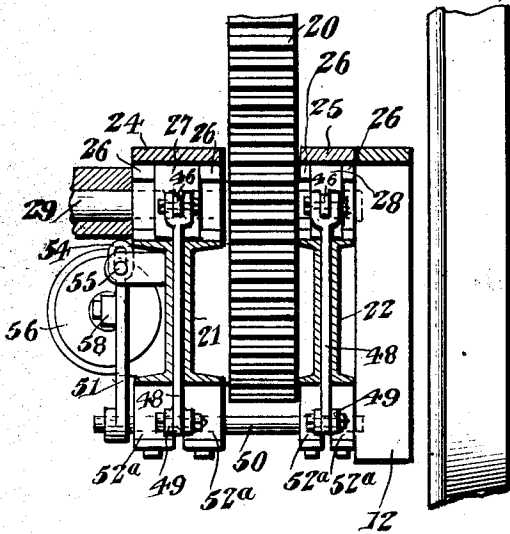
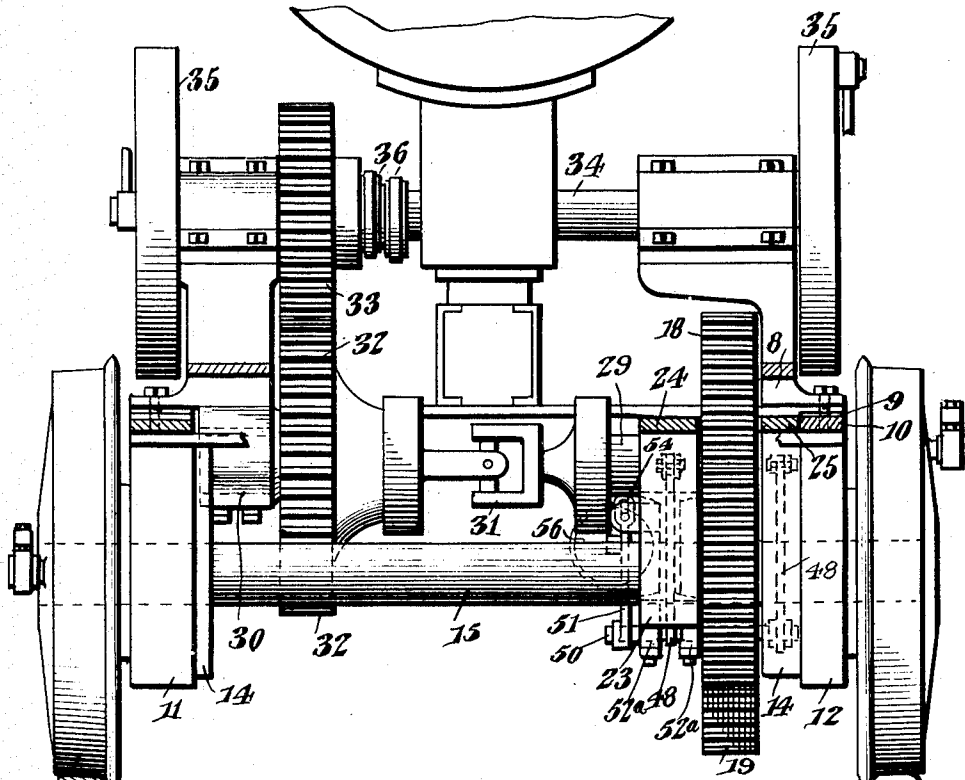

Fig. 3.

Fig. 4.



John Earl Fryermood, Inventor

Witnesses
Jas. K. McCathran
Lamus E. Julihn

By

E. G. Singer

Attorney

J. E. FRIERMOOD
LOCOMOTIVE.

APPLICATION FILED JULY 12, 1906.

3 SHEETS—SHEET 3.

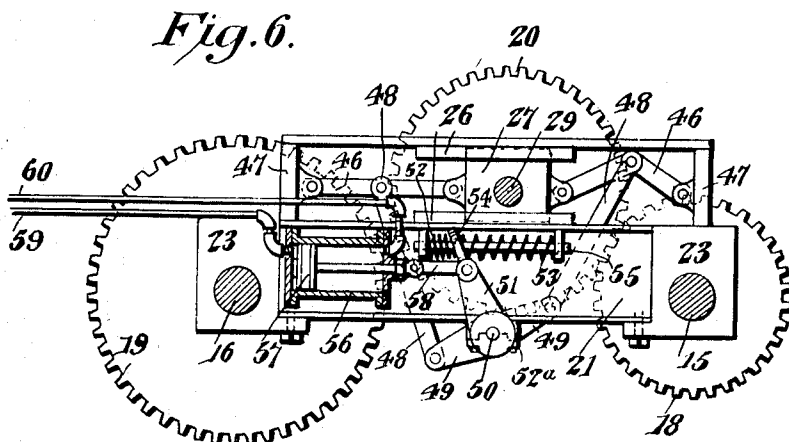
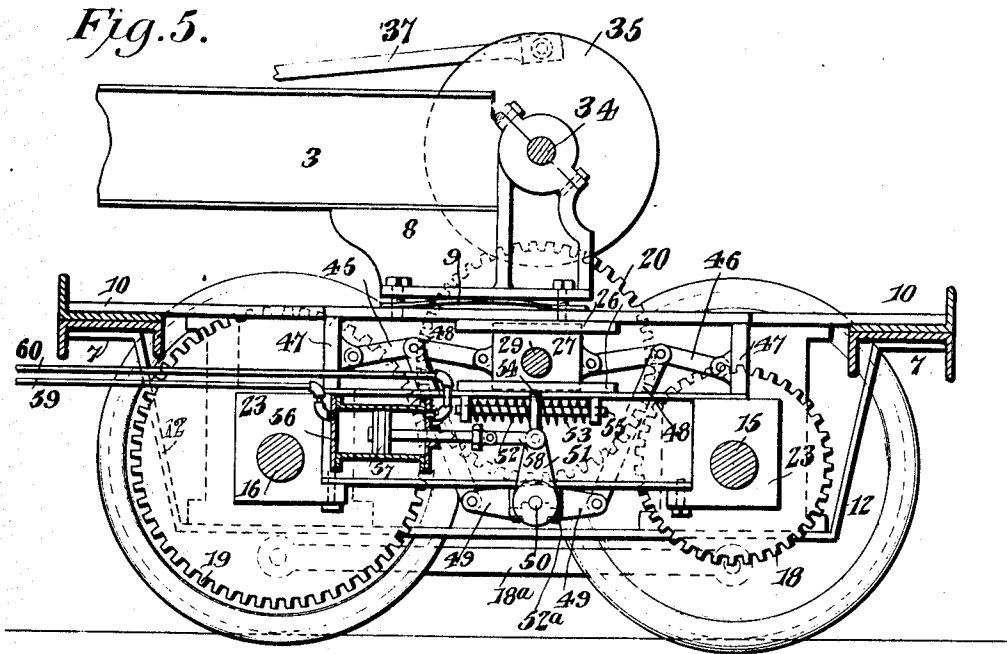

John Earl Frierhood, Inventor

Witnesses
Jas. V. McCathran
Louis S. Julihn

By *E. J. Figgis*
Attorney

UNITED STATES PATENT OFFICE.

JOHN EARL FRIERMOOD, OF EVERETT, WASHINGTON.

LOCOMOTIVE.

No. 870,769.

Specification of Letters Patent.

Patented Nov. 12, 1907.

Application filed July 12, 1906. Serial No. 325,913.

To all whom it may concern:

Be it known that I, JOHN EARL FRIERMOOD, a citizen of the United States, residing at Everett, in the county of Snohomish and State of Washington, have invented a new and useful Locomotive, of which the following is a specification.

This invention relates to improvements in locomotives, and more particularly locomotives of that type in which motion is transmitted from the engine piston to the driving axles through the medium of interposed gearing. Locomotives of this type are ordinarily employed for heavy hauling, as for instance, in logging and mining operations, and while capable of exerting great tractive force, are inefficient for several reasons. In the first place, being primarily work engines, they are geared for low speed, and are incapable of high speed, even when running light, as for instance, when returning with empty cars to the point of loading. Furthermore, the gears are subjected to excessive wear both by reason of the character of the gear mountings and also by reason of the fact that the gearing is in action even when the locomotive is running down grade with the throttle closed. In addition to these inefficiencies, geared locomotives of some makes employ flexible line shafts, the strains on which are excessive, particularly in rounding curves.

Having in mind these commonly recognized deficiencies, the object of my invention is to produce a geared locomotive, including provision for reorganizing the gearing and for totally disconnecting the same, in order that the locomotive may be geared low for a heavy load or steep grades, geared high for making quick return runs with "empties", or thrown entirely out of gear to save the wear and tear on the parts when running down grades.

Another object of the invention is to provide valve-controlled, fluid-operated gear controlling mechanism whereby the changing of the gearing, as well as its connection and disconnection, will be under the control of the engineer, but accomplished by fluid pressure.

A still further object of the invention is to reduce the wear and strains and to avoid any tendency of the trucks to climb the rails, by mounting the driving gears on the engine frame and the driven gears on the driving axles, and by providing intermediate gearing including flexibly connected gears one of which is afforded bearings on the engine frame and the other on the boxings of the driving axles, so that the relative vibration of the locomotive and its supporting structure will be absorbed by the flexible connection instead of by the gears.

Other objects, subordinate to those enumerated, will appear as the succeeding description of the illustrated structure is developed.

In the accompanying drawings—Figure 1 is a sec-

tional elevation of a locomotive constructed in accordance with my invention. Fig. 2 is a side elevation of one of the trucks, the adjacent portion of the engine frame and certain elements of the gearing. Fig. 3 is a vertical section designed more particularly to show the mounting for the shaft of the shiftable gear wheel. Fig. 4 is a sectional elevation designed to show the relation of the engine frame, the front truck, and the associated gearing. Fig. 5 is a vertical section of the front truck and associated parts, and showing more particularly the arrangement of the gearing and the gear controlling mechanism, the gearing being shown disconnected. Fig. 6 is a sectional elevation with the parts geared for high speed, and Figs. 7 and 8 are detail sectional views of the gear controlling valve.

Each part is designated by the same reference character in all of the views.

The locomotive is of the double-ended type, and includes a boiler 1 and a cab 2, of usual or preferred construction, and an engine frame 3 preferably including upper and lower I-beams 4 and 5 located at each side of the locomotive. The engine frame is carried by front and rear trucks 6 and 7, in any suitable manner, brackets 8 being secured to the front ends of the upper I-beams 3 and resting upon springs 9 interposed between the brackets and the upper side bars 10 of the trucks to absorb the vibration of the latter, see Figs. 4 and 5.

The side frames 11 and 12 of each truck are provided, as usual, with vertical guides 13 in which are slidably mounted the journal boxes 14 of the front and rear driving axles 15 and 16. At the outer ends of the axles are carried the track wheels 17, the wheels at each side of the truck being connected by a coupling rod 18^a. Keyed or otherwise secured on the axles 15 and 16 are spur gear wheels 18 and 19 of different diameters, either of which is designed to be engaged and driven by a shiftable mounted intermediate gear 20. For convenience of description the gears 18 and 19 will be referred to as the high and low speed axle gears and the gear 20 as the shiftable intermediate gear. Since the gear 20 is designed to mesh with and drive the gears 18 and 19 rigid with the axles, it is necessary to mount the gear 20 on a support which will move with the axles as the positions of the latter vary with respect to the engine frame, particularly in passing over a poor road bed or around curves. For this reason the mounting for the gear 20 is supported from the axles and is preferably secured to the journal boxes at one side of the truck. For instance, in the illustrated structure, two I-beams 21 and 22, see Fig. 3, extend from one axle to the other in spaced relation, in order to permit the interposition of the wheel 20. The outer beam 22 is supported at its opposite ends by the journal boxes 14, while the inner beam 21 is supported at its opposite ends by sup-

plemental boxes 23 carried by the driving axles at the inner side of the gears, see Figs. 4, 5 and 6.

Above the beams, and spaced therefrom, are a pair of horizontal plates 24 and 25 likewise supported from the boxes 14 and 23. The I-beams and plates are provided with longitudinal guides 26 between which reciprocate a pair of sliding boxes 27 and 28 in which is journaled a shiftable shaft section 29 to which the shiftable gear 20 is keyed. Thus, while the gear 20 is shiftable back and forth between the gears 18 and 19, there is no relative vibration of the engaged gears for the reason that the gear 20 as well as the gears 18 and 19 are supported from the axles of the truck.

Journaled in the bracket 8 at the other side of the locomotive is a fixed or non-shiftable shaft section 30 connected to the shiftable shaft section 29 by a flexible coupling 31 and carrying a non-shiftable intermediate gear 32 meshing with a gear 33 keyed upon the crank shaft 34 journaled in the brackets 8 at opposite sides of the locomotive and provided with crank wheels 35 and eccentrics 36, see Fig. 4. It will be noted that the non-shiftable section 30 of the intermediate shaft is supported by the engine frame, while the shiftable section 29 of said shaft is supported from the axles. It will be evident, therefore, that the flexible coupling 31 between the shaft section not only permits the shifting of the section 29, but also absorbs the relative vibration of the axles and engine frame in order to prevent such vibration, when traversing an uneven piece of track or rounding curves, from racking the gearing, the gears 32 and 33 moving together with the engine frame, and the gears 18, 19 and 20 moving as a unit with the axles.

The shaft 34, which is the driving shaft of the mechanism, is connected by means of the crank wheels 35 and pitman 37 with cross-heads 38 movable on the guide 39. The cross-head 38 is connected to the double-ended piston rod 40 of a piston 41 reciprocating in a cylinder 42 secured to the side of the engine frame intermediate of the trucks and preferably somewhat forward of the cab. These connections between the piston 41 and the front driving shaft 34 are of course duplicated between the piston and the rear driving shaft, see Fig. 1, the only difference being that the rear end of the piston rod is longer than the front end thereof because of the greater interval between the cylinder and the rear driving shaft, the rod being therefore provided with an intermediate cross-head 43 supporting the piston rod at a point intermediate of the rear cross-head 38 and the cylinder.

The cylinder 42 receives steam from the dome of the boiler through a steam pipe 44 and is controlled, as usual, from the throttle, which also serves to control the engine mounted at the opposite side of the locomotive, it being understood that the cylinders and the connections thereof with the front and rear driving shafts, are the same at both sides of the structure. It will also be understood that the cylinder valves are operated by valve gears driven in the usual manner from the eccentrics 36 on the front driving shaft. It will now be seen that the front and rear driving shafts are driven from the engines at opposite sides of the locomotive and are geared to the driving axles through the medium of gearing which may be reorganized for high or low

speed or totally disconnected from the axles, and which comprises two units and an intermediate flexible coupling, one unit being mounted on the engine frame and the other on the axles so that relative vibration of the axles and frame is absorbed by the flexible coupling and not by the gears, thus eliminating the greatest element of wear and avoiding the torsional strains usually incidental to the operation of geared locomotives. In addition to this novel arrangement of the gearing, I have provided means for shifting the gear 20 in a direction transverse to its axis for the purpose of presenting it in mesh with the gear 18 for high speed, the gear 19 for low speed, or in an intermediate disconnected position in order to avoid wear incidental to the operation of the gearing in descending grades, and also to enable the driving mechanism to be instantly disconnected from the wheels when the brakes are applied. Attention may also be directed to the fact that this disconnection of the gearing minimizes the liability of the locomotive to climb the rails when descending grades at high speed or in the event of a runaway.

To accomplish the shifting of the gear 20, I connect to the opposite ends of each sliding journal box 27 and 28 a pair of toggles 45 and 46, see Fig. 5, having their outer ends connected to fixed parts 47. To the knuckles of these toggles are connected depending links 48 pivotally connected at their lower ends to oppositely extending arms 49 constituting elements of a rocker which also includes a rock shaft 50 provided at its inner end with a crank 51 and journaled in suitable bearings 52^a secured to the under sides of the I-beams 31 and 32, see Figs. 3, 5 and 6. The crank 51 is retained in an intermediate position by springs 52 and 53 opposed to the opposite sides of a slotted extension 54 of the crank 51, see Figs. 3 and 5, said springs encircling a guide rod 55 which is passed through the slotted extension 54 of the crank and retained at its opposite ends by lugs which serve as abutments for the outer ends of the springs. When the crank 51 is in the intermediate position shown in Fig. 5, where it is retained by the springs 52 and 53, as stated, the gear 20 will occupy its intermediate disconnected position, sufficient clearance being afforded between said gear and the gears 18 and 19 to prevent accidental engagement. If now, it is desired to gear the locomotive for high speed, it is simply necessary to throw the crank 51 to the left, as shown in Fig. 6, which will swing the rocker to straighten out the toggles 45 and allow the toggles 46 to flex upwardly. This operation of the toggles 45 will shift the journal boxes 27 and 28 to the right, or front, thus moving the gear 20 into mesh with the gear 18. If, on the contrary, it is desired to gear the engine for low speed, or great tractive force, as for instance for hauling a heavily loaded train, the rocker 50 is swung in the reverse direction, either from its intermediate position shown in Fig. 5, or from its high speed position shown in Fig. 6. The result of this reverse operation of the rocker will be to straighten out the toggles 46 and flex the toggles 45, thus shifting the gear 20 into mesh with the large axle gear 19.

While the rocker may be operated in a variety of ways, I have devised a simple and efficient form of mechanism whereby steam from the locomotive boiler may be utilized to shift the gearing, the gearing be-

ing placed under the complete control of the engineer by means of a gear controlling valve, the manipulation of which will enable the engineer to instantly disconnect the gearing or gear the engine for high or low speed with as much facility as the operation of the engine can be controlled by the manipulation of the throttle.

Mounted at the rear end of the inner I-beam in any suitable manner, is a comparatively small cylinder 56 in which reciprocates a piston 57 whose rod is connected by a pitman 58 with the crank 51, see Fig. 5. To the opposite ends of this cylinder 56 are led steam pipes 59 and 60 which are also led to the cylinder at the opposite end of the locomotive, as shown in Fig. 1, and communicate by branches 59^a and 60^a with the ports 59^b and 60^b of the casing 61 of the gear controlling valve 62. The valve 62 is in the form of a hollow cylinder 62^a having a lateral port 62^b which normally occupies a position intermediate of the ports 59^b and 60^b so as to close the port of the valve and to place the opposite ends of the cylinders 56 in communication with the exhaust ports 63 opening through one side of the casing 61. The valve 60 is designed to receive steam from the boiler through a steam pipe 64 entering one side wall of the valve casing at the axis of the latter, as shown in Fig. 8.

To facilitate the manipulation of the valve, the latter is provided with a valve lever 65 equipped with a latch 66 designed to engage any one of three notches in a rack 67 formed on the casing 61, as shown in Fig. 7. Thus, if the disconnection of the gearing is desired, the lever 65 is placed in a central position, and as the steam will be exhausted entirely from both ends of both cylinders 56, the springs 52 and 53 will retain the gear shifting rockers in an intermediate position, as shown in Fig. 5. If it is desired to gear the engine for high speed, as shown in Fig. 6, the lever 65 is swung forward to shift the port 62^b of the valve into communication with the port 60^b of the casing, thus admitting steam to the front end of the front cylinder and to the rear end of the rear cylinder 56. The steam pressure will reciprocate the pistons for the purpose of shifting the rockers and thus moving the gears 20 into mesh with the smaller axle gears 18. If, on the contrary, low speed is desired, the lever 65 is shifted in the opposite direction for the purpose of supplying steam to the inner ends of the cylinders 56 and thus reversing the movement of the rockers and gears 20 to bring the latter into mesh with the larger axle gears 19.

It will of course be understood from what has been said that both the gearing and the gear controlling mechanism is of identical construction on both the front and rear trucks, the only difference being that the small axle gear 18 is mounted on the rear axle of the rear truck instead of on the front axle thereof, as in the case of the front truck, other parts being similarly transposed to accommodate this arrangement.

It is thought that from the foregoing, the construction and operation of my locomotive and the many advantages accruing therefrom will be clearly understood by those skilled in the art. It is obvious, however, that the illustrated structure may be varied within wide limits without departing from the spirit of the invention, and I therefore desire to be understood as expressly reserving the right to effect such

changes, modifications, and variations of the construction shown and described, as may come fairly within the scope of the protection prayed.

What I claim is:—

1. In a geared locomotive, the combination with the engine frame and axles, of driving mechanism carried by the frame, and gearing between the driving mechanism and axles, said gearing comprising flexibly connected units disposed transversely of the locomotive and carried by the frame and axles respectively. 70
2. In a geared locomotive, the combination with the engine frame and axles, of driving mechanism carried by the frame, a gear carried by an axle, an intermediate transverse shaft comprising flexibly connected sections one carried by the engine frame and the other by the axle, and intermediate gears mounted on the respective sections of the shaft and geared respectively to the driving mechanism and to the axle gear. 75
3. In a geared locomotive, the combination with a pair of axles, a truck frame carried by the axles and vertically movable thereon, an engine frame supported by the truck frame, driving mechanism carried by the engine frame, an axle gear fixed to one of the axles, a support carried by the axles independently of the truck frame to permit movement of the truck frame independently of the support, a gear mounted on said support and meshing with the axle gear, and a flexible connection between the driving mechanism and the gear mounted on the support. 80
4. In a geared locomotive, the combination with a pair of axles, a truck frame vertically movable thereon, an engine frame carried by the truck frame, a driving shaft on the engine frame, an axle gear on one of the axles, a support mounted independently of the truck frame on the axles to permit the frame to move independently of the support, an intermediate shaft comprising flexible sections one journaled in the engine frame and the other in said support, and intermediate gears mounted on the respective sections of the intermediate shaft and geared respectively to the driving shaft and axle gear. 85
5. In a geared locomotive, the combination with an engine frame, truck frames, and axles, of driving mechanism carried by the engine frame, axle gears carried by adjacent axles, and an intermediate gear shiftable to engage either axle gear and arranged to be driven by the driving mechanism. 90
6. In a geared locomotive, the combination with an engine frame, truck frames, and axles, of driving mechanism, axle gears of different diameters carried by adjacent axles, and an intermediate gear arranged to be operated by the driving mechanism and shiftable into engagement with either axle gear. 95
7. In a geared locomotive, the combination with an engine frame, truck frames, and axles, of driving mechanism carried by the engine frame, axle gears carried by adjacent axles, an intermediate gear also carried by said axles and shiftable to engage either axle gear, and a flexible connection between the driving mechanism and the intermediate gear. 100
8. In a geared locomotive, the combination with the engine frame, truck frames, and axles, of driving mechanism mounted on the engine frame, axle gears mounted on adjacent axles, a shaft having flexibly connected sections one supported by the engine frame and the other from the axles, gearing connecting one of the shaft sections with the driving mechanism, and an intermediate gear mounted on the other shaft section and shiftable into engagement with either of the axle gears. 105
9. In a geared locomotive, the combination with the engine frame, truck frames, and axles, of driving mechanism mounted on the engine frame, axle gears of different diameters mounted on adjacent axles, an intermediate gear supported from said axles independently of the engine frame or truck frames and shiftable into engagement with either axle gear, and gearing between the driving mechanism and the intermediate gear, said gearing including a shaft having flexibly connected sections one of said sections being carried by the engine frame. 110
10. In a geared locomotive, the combination with an engine frame, truck frames, and axles, of axle gears carried

- by adjacent axles, a support extended between and carried by said axles, a journal box slidable on said support, a shaft journaled in said box, an intermediate gear mounted on the shaft and movable with the box to engage either of the axle gears, and a connection between the intermediate gear and the driving mechanism.
11. In a geared locomotive, the combination with an engine frame, truck frames, and axles, of driving mechanism carried by the engine frame, axle gears of different diameters mounted on adjacent axles, a support extending between and carried by said axles, a journal box slidable on the said support, a shaft comprising flexibly connected sections one of which is journaled in the engine frame and the other in the journal box, gearing between said shaft and the driving mechanism, and an intermediate gear mounted on one of the shaft sections and shiftable with the journal box to engage either of the axle gears.
12. In a geared locomotive, the combination with the engine frame, truck frames, and axles, of driving mechanism mounted on the frame, and means for gearing the driving mechanism alternately to different axles.
13. In a geared locomotive, the combination with an engine frame, truck frames, and axles, of driving mechanism mounted on the engine frame, and fluid operated means for throwing the driving mechanism into and out of gear with an axle.
14. In a geared locomotive, the combination with an engine frame, truck frames, and axles, of driving mechanism carried by the engine frame, gearing between the driving mechanism and one of the axles said gearing including a flexible connection to accommodate the relative movement of the engine frame and the driven axle and also including two gears one of which is carried by an axle, and means for throwing said gears into and out of gear.
15. In a geared locomotive, the combination with an engine frame, truck frames, and axles, of driving mechanism mounted on the engine frame, an axle gear fixed to one of the axles, and gearing between the driving mechanism and said axle gear, said gearing including a flexible connection accommodating the relative movement of the engine frame and axle and also including a gear shiftable into and out of mesh with the axle gear.
16. In a geared locomotive, the combination with the engine frame, truck frames, and axles, of driving mechanism, an axle gear fixed to one of the axles, a support carried by said axle, and gearing between the driving mechanism and the axle gear, said gearing including a gear wheel shiftable on the support to engage the axle gear.
17. In a geared locomotive, the combination with an engine frame, truck frames, and axles, of driving mechanism mounted on the engine frame, a support extending between adjacent axles and carried thereby independently of the truck frame, an axle gear fixed to one of said axles, and gearing between the driving mechanism and the axle gear, said gearing including a flexible connection accommodating the relative movement of the engine frame and axles and also including a gear shiftable on the support to engage or disengage the axle gear.
18. In a geared locomotive, the combination with an engine frame, cab, truck frames and axles, of driving mechanism, gearing between the driving mechanism and an axle, and fluid-operated gear controlling mechanism including a manually-operated device located in the cab of the locomotive.
19. In a geared locomotive, the combination with an engine frame, truck frames and axles, of driving mechanism, gearing between the driving mechanism and an axle, gear controlling means supported by the axle, and a manually-operated member controlling the operation of said means and supported from the engine frame.
20. In a geared locomotive, the combination with the engine frame, truck frames, and axles, of driving mechanism, gearing between the driving mechanism and an axle, and fluid-operated gear controlling mechanism operative to cause the connection or disconnection of the driving mechanism and axle.
21. In a geared locomotive, the combination with the engine frame, cab, truck frames, and axles, of driving mechanism, gearing between the driving mechanism and one of the axles, fluid-operated means supported from adjacent axles to move the gearing into and out of gear, and means located in the locomotive cab and controlling the operation of said fluid-operated means.
22. In a geared locomotive, the combination with the engine frame, truck frames, and axles, of driving mechanism, gearing between the driving mechanism and an axle, and fluid-operated means controlling the operative connection between the driving mechanism and axle, said means including a cylinder, a piston therein, and a controlling valve for the motive fluid.
23. In a geared locomotive, the combination with a cab, engine frame, truck frames, and axles, of driving mechanism, gearing between the driving mechanism and an axle, and means controlling the operative connection between the driving mechanism and said axle, said means including a cylinder supported from the axle, a piston in the cylinder, and a valve controlling the supply of motive fluid to the cylinder and located in the locomotive cab.
24. In a geared locomotive, the combination with the engine frame, truck frames, and axles, of driving mechanism, gearing between the driving mechanism and one of the axles and including a shiftable member, and fluid-operated means for shifting said member.
25. In a geared locomotive, the combination with an engine frame, truck frames, and axles, of driving mechanism, gearing between the driving mechanism and one of the axles and including a gear wheel shiftable into and out of gear, and fluid-operated means for shifting said gear wheel.
26. In a geared locomotive, the combination with a cab, engine frame, truck frames, and axles, of driving mechanism, gearing, between the driving mechanism and an axle, including a shiftable gear wheel, fluid-operated mechanism for shifting the gear wheel, and a valve located in the locomotive cab and controlling the supply of motive fluid to the fluid-operated shifting mechanism.
27. In a geared locomotive, the combination with an engine frame, truck frames, and axles, of driving mechanism, gearing between the driving mechanism and one of the axles and including a shiftable gear wheel, fluid-operated means supported from the axle and operative to shift the gear wheel, and a fluid controlling valve supported from the engine frame.
28. In a geared locomotive, the combination with the engine frame, truck frames, and axles, of driving mechanism, an axle gear fixed to one of the axles, gearing between the driving mechanism and the axle gear and including a shiftable gear wheel supported from adjacent axles and movable into and out of mesh with the axle gear, and fluid-operated means for shifting said gear.
29. In a geared locomotive, the combination with the engine frame, truck frames, and axles, of a support extending between and carried by adjacent axles, an axle gear fixed to one of the axles, driving mechanism, and gearing connecting the driving mechanism with an axle and including a gear wheel shiftable on the support to engage and disconnect the axle wheel, and fluid-operated mechanism also mounted on the support and operative to shift the gear wheel.
30. In a geared locomotive, the combination with the engine frame, truck frames, and axles, of driving mechanism, an axle gear, gearing between the driving mechanism and axle, including a gear wheel shiftable into and out of mesh with the axle gear, a spring retaining the gear wheel in one position, and fluid-operated means for moving said gear wheel to another position in opposition to the spring.
31. In a geared locomotive, the combination with the engine frame, truck frames, and axles, of driving mechanism, gearing connecting the driving mechanism to the axle, an element shiftable to bring the gearing into gear, and means including a toggle for shifting said element.
32. In a geared locomotive, the combination with the engine frame, truck frames, and axles, of driving mechanism, gearing between the driving mechanism and an axle and including a shiftable element, and a fluid-operated toggle for shifting said element.
33. In a geared locomotive, the combination with the engine frame, truck frames, and axles, of driving mechanism, gearing between the driving mechanism and an axle and including a shiftable element, a spring yieldingly

- retaining said element in one position, and a toggle for moving said element in opposition to the spring.
34. In a geared locomotive, the combination with the engine frame, truck frames, and axles, of driving mechanism, gearing between the driving mechanism and an axle and including a shiftable element, a spring yieldingly retaining said element in one position, and a fluid-operated toggle for moving such element in opposition to the spring. 5
35. In a geared locomotive, the combination with the engine frame, truck frames, and axles, of driving mechanism, gearing between the driving mechanism and an axle, including a shiftable gear wheel, a shaft carrying said wheel, a shiftable journal box for said shaft, and a toggle operative to shift the journal box. 10
36. In a geared locomotive, the combination with the engine frame, truck frames, and axles, of driving mechanism, an axle gear, intermediate gearing including a gear wheel shiftable into and out of mesh with the axle gear, a shaft for the shiftable gear wheel, a shiftable journal box for said shaft, and a fluid-operated toggle for moving the box. 15
37. In a geared locomotive, the combination with the engine frame, truck frames, and axles, of driving mechanism, gearing intermediate of the driving mechanism and an axle and including a member shiftable into and out of operative position, a toggle for shifting said member, a rocker operating the toggle, and fluid-operated means for moving the rocker. 20
38. In a geared locomotive, the combination with an engine frame, truck frames, and an axle, of a support extending between and supported by the adjacent axles, driving mechanism, gearing between the driving mechanism and an axle, said gearing including an axle gear fixed to the axle and an intermediate gear shiftable into and out of engagement with the axle gear, said shiftable gear being mounted on the support extended between the axles, a rocker also mounted on said support, and a toggle arranged to shift the gear and operated by the rocker. 25
39. In a geared locomotive, the combination with the engine frame, truck frames, and axles, of a support extending between adjacent axles and carried thereby independently of the truck frames, driving mechanism carried by the engine frame, an axle gear fixed to one of the axles, gearing interposed between the driving mechanism and the axle gear and including an intermediate gear wheel shiftable into and out of operative position, a shaft for the shiftable gear wheel, journal boxes supporting said shaft and shiftable on the support which extends between the axles, a rocker also mounted on the support and operatively connected to the journal boxes to shift the same, a cylinder mounted on the support, means for supplying motive fluid thereto, and a piston movable in the cylinder and connected to the rocker to operate the same. 30
40. In a geared locomotive, the combination with the engine frame, truck frames, and axles, of driving mechanism carried by the engine frame, an axle gear fixed to one of the axles, a support extending between and carried by adjacent axles, sliding journal boxes, a rocker and a cylinder all carried by said support, a shaft mounted in the journal boxes, gearing between the driving mechanism and the axle gear and including a gear wheel mounted on the shaft and shiftable therewith to engage and disconnect the axle gear, a toggle arranged to move the journal boxes to shift the gear wheel, a connection between said toggle and the rocker, a piston mounted to reciprocate in the cylinder and connected to the rocker, and means for supplying motive fluid to the cylinder. 35
41. In a geared locomotive, the combination with the engine frame, truck frames, and axles, of driving mechanism, and fluid-operated mechanism for throwing the driving mechanism into operative relation with different axles alternately. 40
42. In a geared locomotive, the combination with the engine frame, truck frames, and axles, of driving mechanism, gearing, and fluid-operated means for establishing connection between the driving mechanism and either of two axles through the medium of said gearing. 45
43. In a geared locomotive, the combination with the engine frame, truck frames, and axles, of axle gears of different diameters fixed to adjacent axles, an intermediate gear adapted to engage either of said axle gears, fluid-operated mechanism for shifting the intermediate gear, and gearing between the intermediate gear and the driving mechanism. 50
44. In a geared locomotive, the combination with the cab, engine frame, truck frames, and axles, of axle gears of different diameters fixed to adjacent axles, driving mechanism, gearing for connecting the driving mechanism with either axle gear and including a gear wheel shiftable into engagement with either axle gear, fluid-operated mechanism for shifting the intermediate gear, and a controlling valve located in the locomotive cab and controlling the operation of the gear shifting mechanism. 85
45. In a geared locomotive, the combination with an engine frame, truck frames, and axles, or driving mechanism carried by the engine frame, gearing adapted to connect the driving mechanism to either of two axles, and fluid-operated gear controlling mechanism. 90
46. In a geared locomotive, the combination with the engine frame, truck frames, and axles, of driving mechanism carried by the engine frame, gearing for connecting the driving mechanism with either of two adjacent axles, a support extending between said axles and carried thereby, fluid-operated gear controlling means carried by said support, and a controlling valve for said means. 100
47. In a geared locomotive, the combination with the engine frame, truck frames, and axles, of axle gears carried by adjacent axles, a gear wheel shiftable to engage either axle wheel, a support extending between and carried by the axles, means mounted on said support for shifting the gear wheel, and an operative connection between said gear wheel and the driving mechanism. 105
48. In a geared locomotive, the combination with the engine frame, truck frames, and axles, of driving mechanism, axle gears of different diameters fixed to adjacent axles, a support extending between and carried by said axles, a gear wheel carried by said support and shiftable to engage either axle wheel, fluid-operated means carried by said support to shift the gear wheel, and an operative connection between the shiftable gear wheel and the driving mechanism. 110
49. In a geared locomotive, the combination with an engine frame, truck frames, and axles, of axle gears fixed to adjacent axles, a support extending between said axles and carried thereby, a gear wheel shiftable on said support to engage either axle wheel, a rocker also carried by the support and movable to shift the gear wheel, and means for operating the rocker. 115
50. In a geared locomotive, the combination with the engine frame, truck frames, and axles, of driving mechanism, gearing including a shiftable element movable to cause an operative connection to be established between the driving mechanism and either of two axles, and toggle mechanism for moving said shiftable member in opposite directions. 120
51. In a geared locomotive, the combination with the engine frame, truck frames, and axles, of axle gears fixed to adjacent axles, an intermediate gear shiftable to engage either axle gear, toggle mechanism for shifting said intermediate gear, and driving mechanism for said gear. 125
52. In a geared locomotive, the combination with the engine frame, truck frames, and axles, of axle gears fixed to adjacent axles, an intermediate gear shiftable to engage either axle gear, toggles for shifting said intermediate gear, and operating means common to said toggles. 130
53. In a geared locomotive, the combination with the engine frame, truck frames, and axles, of axle gears fixed to adjacent axles, an intermediate gear shiftable to engage either axle gear, toggles for moving the intermediate gear in opposite directions, and a rocker connected to said toggles. 135
54. In a geared locomotive, the combination with an engine frame, truck frames, and axles, of axle gears fixed to adjacent axles, an intermediate gear shiftable to engage either axle gear, driving mechanism for the intermediate gear, and a fluid-operated toggle for shifting said gear. 140
55. In a geared locomotive, the combination with the engine frame, truck frames, and axles, of axle gears fixed to adjacent axles, an intermediate gear shiftable to engage 145
56. In a geared locomotive, the combination with the engine frame, truck frames, and axles, of axle gears fixed to adjacent axles, an intermediate gear shiftable to engage 150
57. In a geared locomotive, the combination with the engine frame, truck frames, and axles, of axle gears fixed to adjacent axles, an intermediate gear shiftable to engage 155
58. In a geared locomotive, the combination with the engine frame, truck frames, and axles, of axle gears fixed to adjacent axles, an intermediate gear shiftable to engage 160

- either axle gear, driving means for the intermediate gear, toggles for shifting the intermediate gear, a rocker for operating the toggles, and fluid-operated means for moving the rocker.
- 5 56. In a geared locomotive, the combination with the engine frame, truck frames, and axles, of driving mechanism, gearing for connecting the driving mechanism to either of two axles, said gearing including a shiftable member, means yieldingly retaining said member in an intermediate position, and means for positively moving said member in either direction from said position.
- 10 57. In a geared locomotive, the combination with the engine frame, truck frames, and axles, of axle wheels carried by adjacent axles, an intermediate gear wheel shiftable to engage either axle wheel, means for yieldingly retaining the gear wheel in an intermediate position and out of operative relation with both axle wheels, and means for shifting the gear wheel into engagement with either axle gear.
- 15 58. In a geared locomotive, the combination with the engine frame, truck frames, and axles, of axle gears carried by adjacent axles, an intermediate gear shiftable to engage either axle gear, means yieldingly retaining the shiftable gear in an intermediate position, and fluid-operated means for shifting the intermediate gear in either direction to engage an axle gear.
- 20 59. In a geared locomotive, the combination with the engine frame, truck frames, and axles, of axle gears carried by adjacent axles, an intermediate gear shiftable to engage either axle gear, a rocker movable to shift the intermediate gear, counter active springs coacting with the rocker to throw the intermediate gear into disconnected position, and fluid-operated means for moving the rocker to shift the intermediate gear into engagement with either of the axle gears.
- 25 60. In a geared locomotive, the combination with the engine frame, truck frames, and axles, of driving mechanism, gearing adapted to connect the driving mechanism with either of two axles, and gear controlling mechanism including a cylinder, a piston therein, means for leading motive fluid to the opposite ends of the cylinder, and a controlling valve movable to permit the motive fluid to be supplied to either end of the cylinder and exhausted from the opposite end thereof or to place both ends of the cylinder in communication with the exhaust.
- 30 61. In a geared locomotive, the combination with the engine frames, axles, and truck frames movable relative to the axles and supporting the engine frame, of driving mechanism mounted on the engine frame, a shaft disposed transversely of the locomotive and comprising flexibly connected sections operatively related to the driving mechanism and an axle respectively.
- 35 62. In a geared locomotive, the combination with the engine frame, axles, and truck frames movable relative to the axles and supporting the engine frame, of driving mechanism mounted on the engine frame and including a driving shaft disposed transversely of the locomotive adjacent to one of the truck frames, and a second shaft also disposed transversely of the locomotive and having flexibly connected sections, one of which is geared to the driving shaft and the other of which is geared to an axle.
- 40 63. In a geared locomotive, the combination with the engine frame, truck frames and axles, of a shaft disposed transverse to the locomotive and comprising flexibly connected sections, driving mechanism mounted on the engine frame and arranged to drive said shaft, and variable gearing whereby the axles of the locomotive may be driven at relatively high or low speed through the medium of the transverse shaft.
- 45 64. In a geared locomotive, the combination with an engine frame, truck frames and axles, of transverse driving shafts mounted on the engine frame over the truck frames, driving mechanism mounted on the engine frame and arranged to operate the driving shafts, and gearing between each of said driving shafts and an axle.
- 50 65. In a geared locomotive, the combination with the engine frame, truck frames and axles, of driving mechanism on the engine frame, transverse driving shafts located adjacent to the opposite ends of the engine frame and arranged to be driven by the driving mechanism, gearing between each driving shaft and an axle, and means for throwing the gearing into and out of gear.
- 55 66. In a geared locomotive, the combination of an engine frame, truck frames and axles, of driving mechanism on the engine frame, transverse driving shafts likewise mounted on the engine frame, separate sets of gearing connecting the respective shafts to different axles, and means for changing the speed of said gearing.
- 60 67. A geared locomotive including axles, truck frames supported by the axles and movable relative thereto, an engine frame supported by the truck frames, driving mechanism mounted on the engine frame, gearing between the driving mechanism and an axle, said gearing being mounted independently of the adjacent truck frame to prevent racking of the gearing by the vibration of said truck frame, and means for shifting an element of said gearing to disconnect said axle and to operatively connect a different axle to the driving mechanism.
- 65 68. A geared locomotive including axles, truck frames, springs supporting the truck frames from the axles and permitting movement of said frames relative to the axles, an engine frame carried by the truck frames, said truck frames having limited movement relative to the engine frame, driving mechanism mounted on the engine frame, and gearing, the elements of which gearing are supported from the engine frame and axles exclusively to prevent racking of the gearing by the vibration of a truck frame and said gearing including units disposed transversely of the locomotive and relatively movable to accommodate the relative movement of the engine frame and axles.
- 70 69. In a geared locomotive, the combination with an engine frame, truck frames, and axles, of driving mechanism, and means for operatively connecting the driving mechanism with different axles alternately.
- 75 70. In a geared locomotive, the combination with an engine frame, truck frames, and axles, of driving mechanism, and means for operatively connecting the driving mechanism with different axles alternately, said means being arranged to drive one axle at a greater speed than the other.
- 80 81. In testimony, that I claim the foregoing as my own. I have hereto affixed my signature in the presence of two witnesses.
- 85
- 90
- 95
- 100
- 105
- 110
- 115
- 120

JOHN EARL FRIERMOOD.

Witnesses:

SCHUYLER DURYEE,
DANIEL F. DURYEE.